

EPHY MESS

Gesellschaft für Elektro-Physikalische Meßgeräte mbH



Speed sensors

Leuchtturm
Automation

深圳市朝瑞自动化系统有限公司



Content

1	Introduction.....	2
2	Overview of speed sensor housings.....	3
3	Electric data.....	5
3.1	Electric data of the dc-voltage powered speed sensor	5
3.2	Electric data of the current-loop speed sensor	5
3.3	Electric data of the high voltage 110 V DC speed sensor.....	5
4	Electrical protection	6
5	Mechanical parameters	6
6	Mechanical dimensions of the sensor housing	7
6.1	Drawing no. 1: DWG 04 - Flange version	7
6.2	Drawing no. 2: DWG 05 - Right angle flange version	8
6.3	Drawing no. 3: DWG 06 - Half flange version.....	9
6.4	Drawing no. 4: DWG 07 - Screw in type	10
6.5	Drawing no. 5: DWG 08 - Asymmetrical flange version.....	11
6.6	Drawing no. 6: DWG 09 - Big flange version	12
6.7	Drawing no. 7: DWG 21 - Flat housing with cable aside version	13
6.8	Drawing no. 8: DWG 22 - Flat housing with cable backside version.....	14
6.9	Drawing no. 9: DWG 41 - Grinding housing version	15
6.10	Drawing no. 10: Mounting plate for version with flange housing.....	16
7	Structure of the match code.....	17
8	Questionnaire for speed sensor specification	20



1 Introduction



Figure 1: EPHY-MESS speed sensors

Robust and reliable speed sensors are essential components of EPHY-MESS portfolio since 1990. EPHY-MESS speed sensors are used worldwide in metros, subway trains and trams. Even under the harsh conditions in the mining they are successfully applied.

Features:

- ▲ reliable detection of rotational direction and rotational speed
- ▲ easy and quick installation
- ▲ shock and vibration resistant in accordance with EN 61 373 cat. 3
- ▲ maintenance and wear free
- ▲ operating temperature up to +125°C
- ▲ compact design

EPHY-MESS produces at the moment following speed sensors:

- ▲ DC voltage supply between 8 V DC and 24 V DC (limit 30 V DC)
- ▲ current loop 7 mA / 14 mA

A special construction is the high-voltage speed sensor for 110 V DC (77.5 V - 137 V). This speed sensor is only with a housing version DWG 41 available. It is designed especially for Ø 200 mm gear wheels with 120 teeth (module 1.67).

This catalog is designed for easier selection of the right speed sensor.



2 Overview of speed sensor housings

This short overview shows you the currently available speed sensor housing versions.

	<p>DWG 04 Straight cable output</p>
	<p>DWG 05 Cable output aside</p>
	<p>DWG 06 Half flange housing, cable output 180°</p>
	<p>DWG 07 Threaded sleeve M20x1,5 straight cable output</p>
	<p>DWG 08 Flange housing with asymmetrical flange</p>





	<p>DWG 09 Big flange version, straight cable output</p>
	<p>DWG 21 / DWG 51 Flat housing, aside cable output</p>
	<p>DWG 22 Flat housing, backside cable output</p>
	<p>DWG 41 Grinding housing</p>
 <p>Mounting Plate for DWG41 replacement</p>	<p>Mounting plate for DWG 04, DWG 05</p>

Figure 2: Housing versions

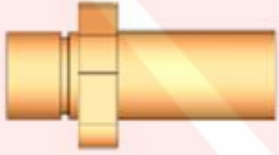
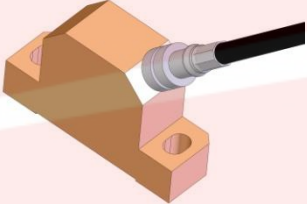

3 Electric data

3.1 Electric data of the dc-voltage powered speed sensor

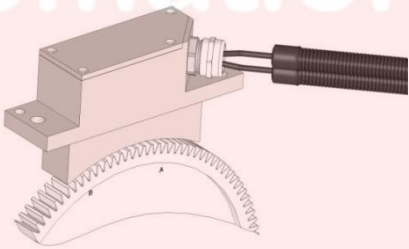
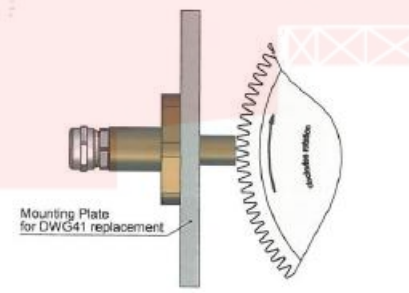
Supply voltage U_B	8 to 24 V DC (max. 30 V DC)
Current demand without load	< 25 mA at 24 V DC
Insulation resistance	>200 M Ω / 500 V DC <small>encoder-electronics to encoder-housing</small>
Max. output current	20 mA
Frequency range	0.01 – 20000 Hz (standard)
Output level	
high-level	$\geq U_B - 2.0$ V (at 1.67 k Ω load resistance)
low-level	$\leq +1,5$ V
Duty cycle	0.5 \pm 0.2 at involute toothing
Reverse polarity protection	yes, for power supply
Short circuit proof	yes, outputs continuously

3.2 Electric data of the current-loop speed sensor

Supply voltage U_B	max. 24 V DC
Insulation resistance	>200 M Ω / 500 V DC <small>encoder-electronics to encoder-housing</small>
Output current	
low-level	7 mA (5.6 – 8.4 mA)
high-level	14 mA (11.2 – 16.8 mA)
Frequency range	0.01 – 20000 Hz (standard)
Duty cycle	0.5 \pm 0.2 at involute toothing
Reverse polarity protection	yes

3.3 Electric data of the high voltage 110 V DC speed sensor

Supply voltage U_B	110 V DC (77.5 – 137 V DC)
Current demand without load	< 80 mA at 110 V DC
Insulation resistance	>200 M Ω / 500 V DC <small>encoder-electronics to encoder-housing</small>
Max. output current	1 mA
Frequency range	0.01 – 20000 Hz (standard)
Output	both outputs galvanically isolated from each other and from power supply
Output level	
direction left	$\sim +2.0$ V ground-referenced
direction right	~ -2.0 V ground-referenced
Duty cycle	25 μ sec
Reverse polarity protection	yes
Short circuit proof	yes, unlimited

Alternatively available with the electrical data of the version with 24 V.



4 Electrical protection

Shielding
ESD-protection

connected to sensor housing
fulfills requirements acc. EN60947-5-2

Electromagnetic Compatibility (EMV)
Vibration resistance
Frequency range

6 kV contact discharge
8 kV air discharge
track vehicles EN 50121-3-2
according EN61373, category 3
200 ... 2000 Hz; 0.5 Oct./min , stimulation: 40 g,
number of axes: 3, duration of test: 20 min per axis

Shock resistance
Protection (DIN EN 60529)
Measuring range
Ambient temperature
Fire protection

according EN61373, category 3, EN 60068-2-27
IP68 (at 8 bar 60 minutes)
-40°C...+125°C
-40°C...+125°C
EN45545-2

5 Mechanical parameters

Material of housing

brass (Ms), stainless steel (VA) 1.4571 on demand
welding housing (DWG 41) only in aluminum with brass
sensor head

Dimensions
Connection

see drawing picture 1 - 9
M16x1.5*
flat housing DW G04 also with M20x1,5**)

* to connect a corrugated pipe, a rubber-textile hose and so on

** not possible for flat housing DWG 21/22.



6 Mechanical dimensions of the sensor housing

6.1 Drawing no. 1: DWG 04 - Flange version

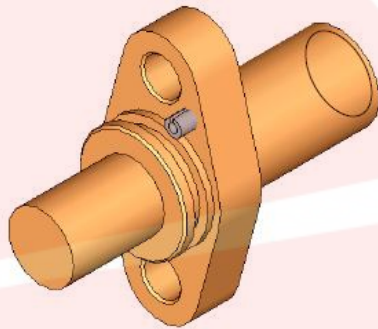

View with clamping pin

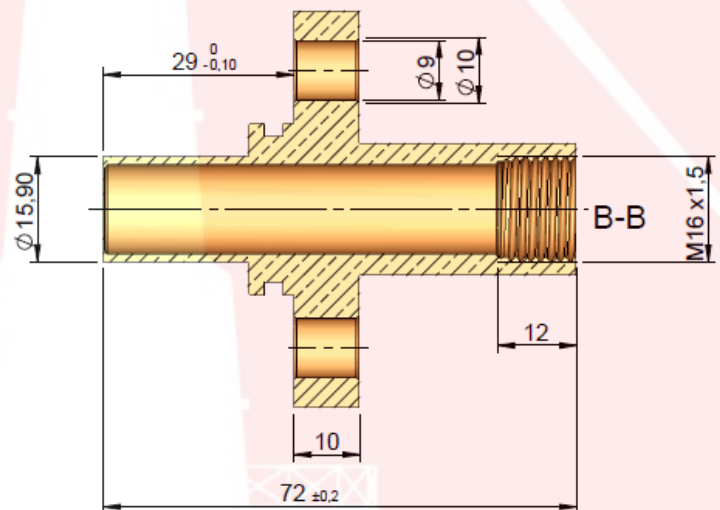
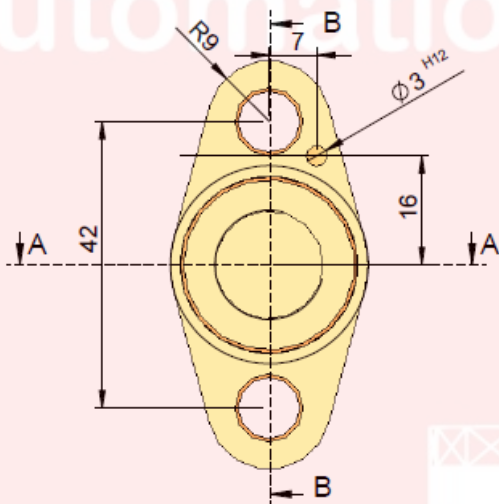
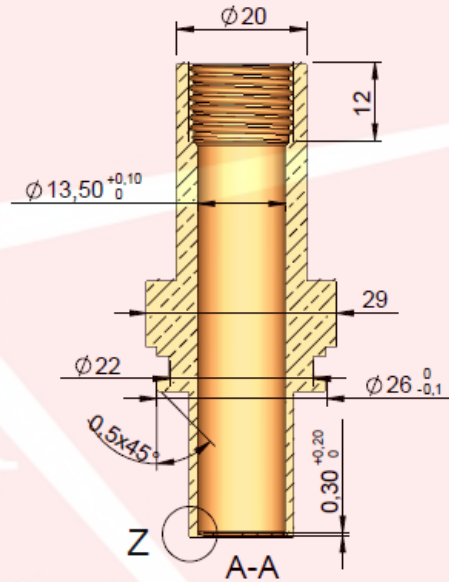



6.2 Drawing no. 2: DWG 05 - Right angle flange version

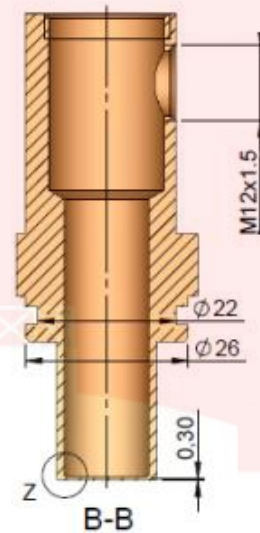
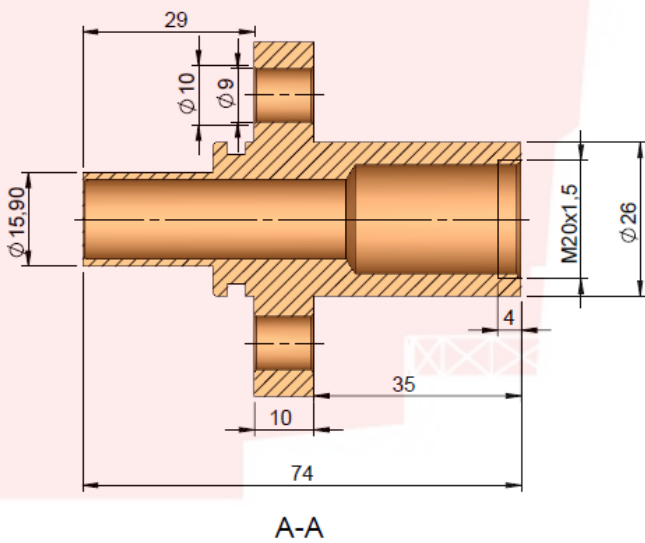
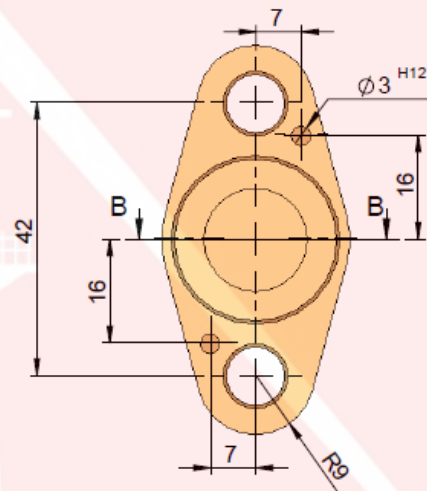
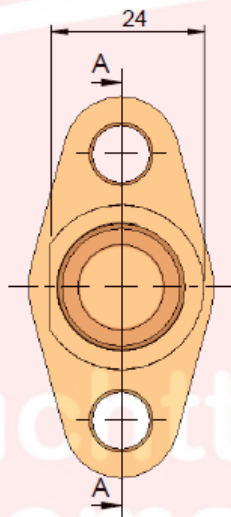
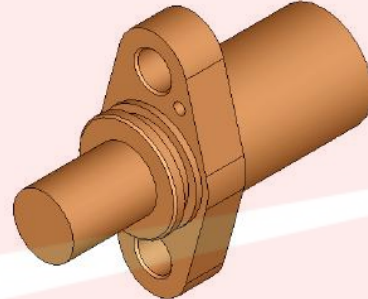
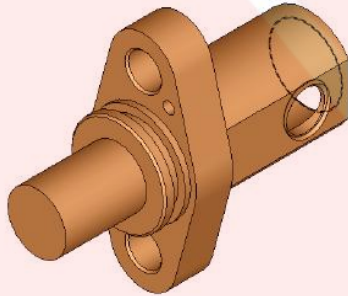



6.3 Drawing no. 3: DWG 06 - Half flange version

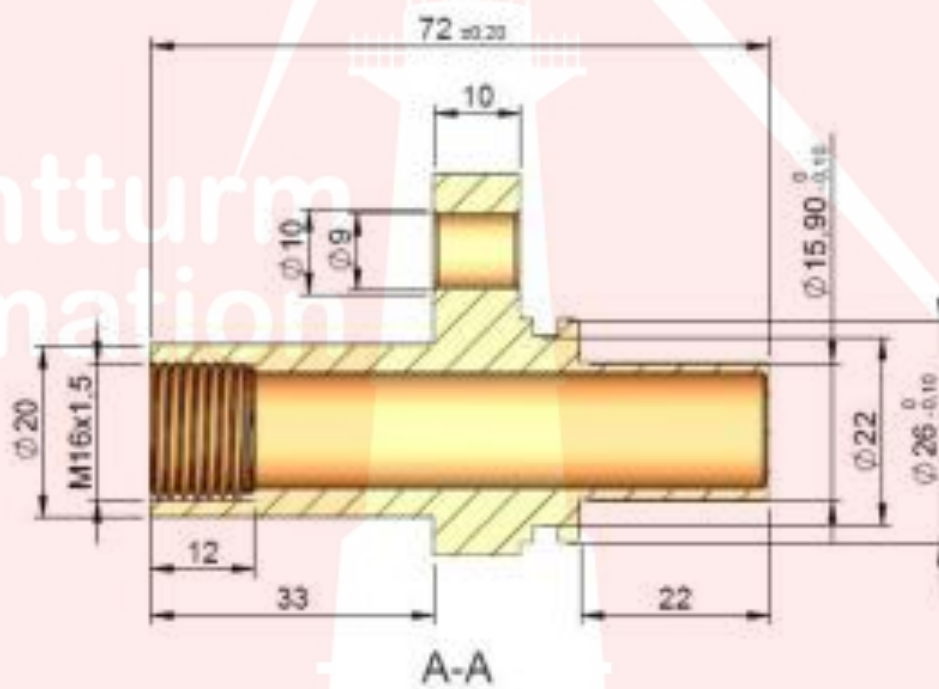
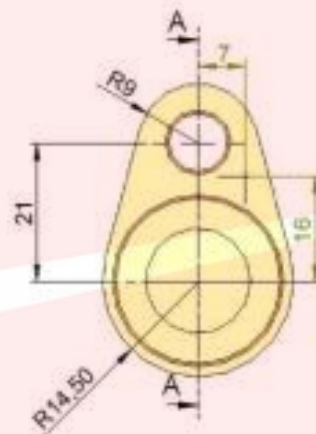

6.4 Drawing no. 4: DWG 07 - Threaded sleeve type

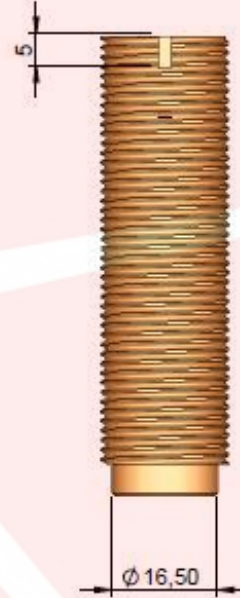
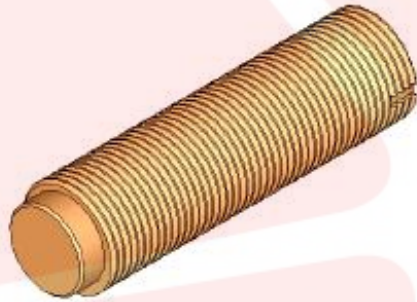

Leuchtturm
Automation

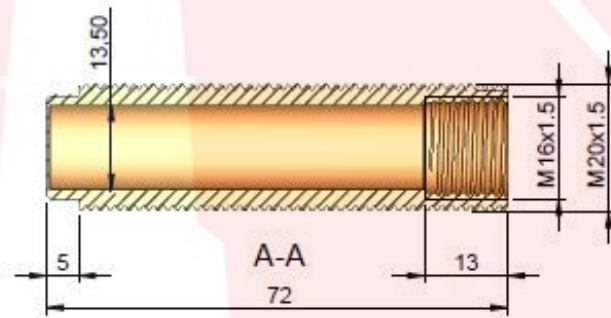



6.5 Drawing no. 5: DWG 08 - Asymmetrical flange version

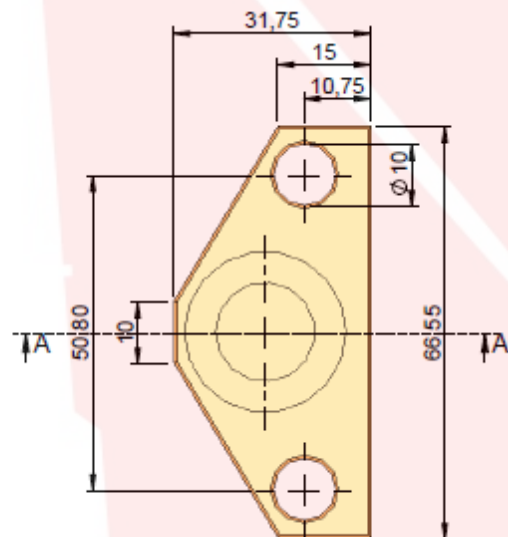
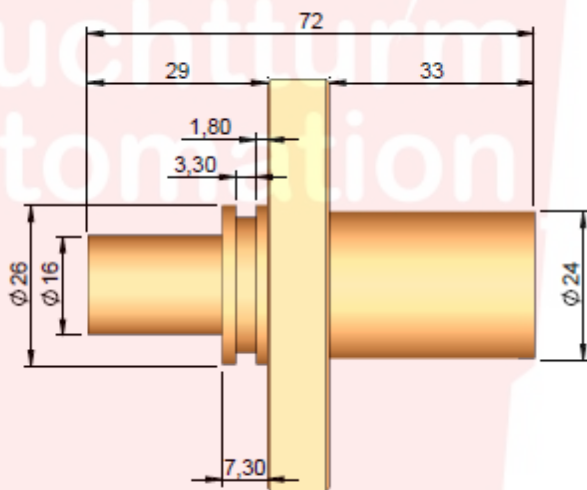
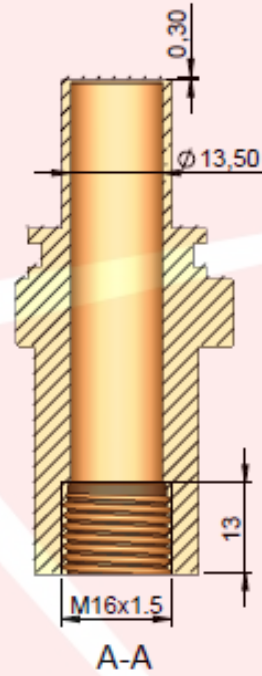
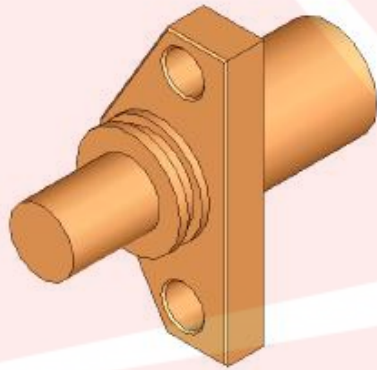



6.6 Drawing no. 6: DWG 09 - Big flange version

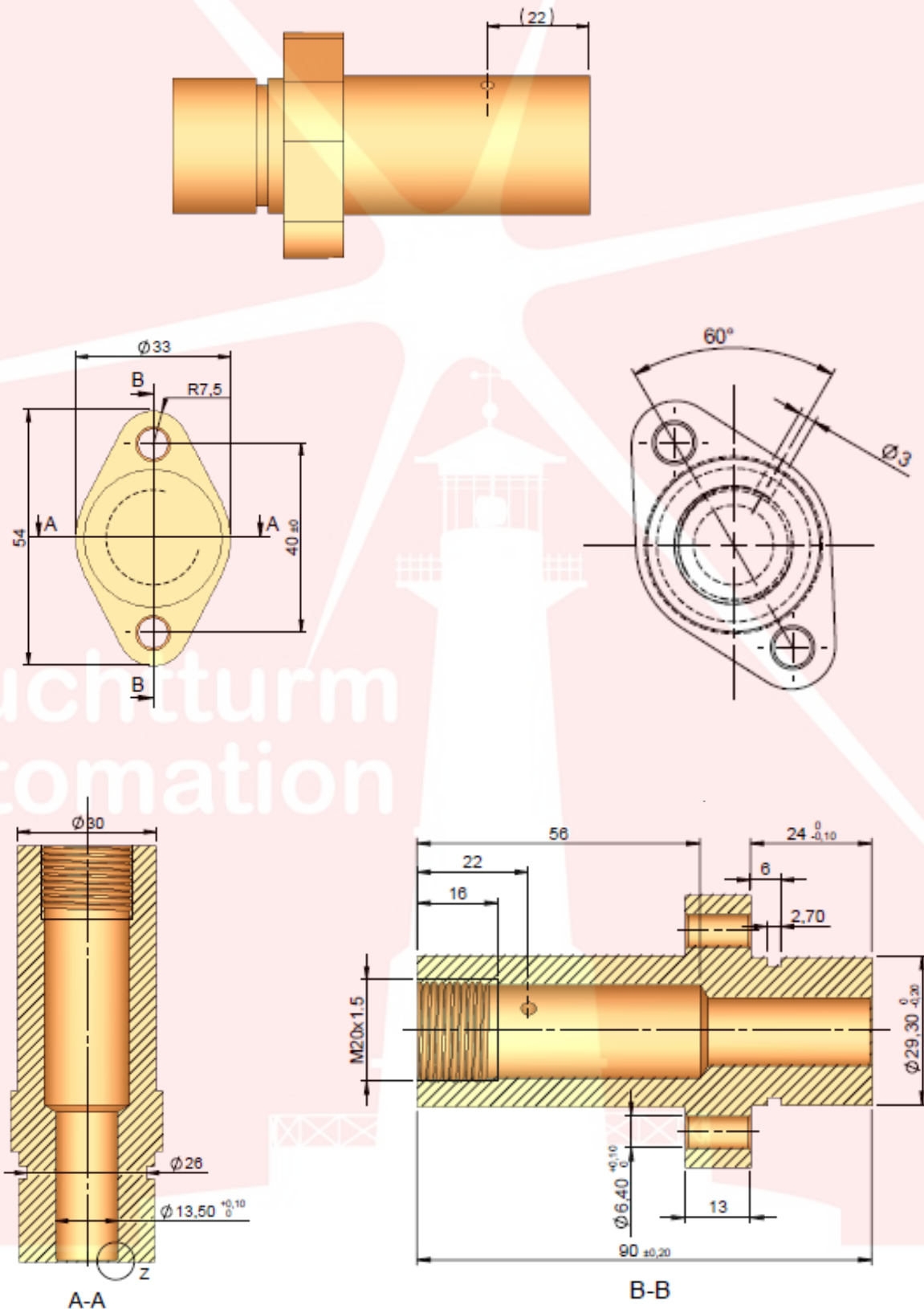

Surface according to DIN ISO 1302



6.7 Drawing no. 7: DWG 21 - Flat housing with cable aside version

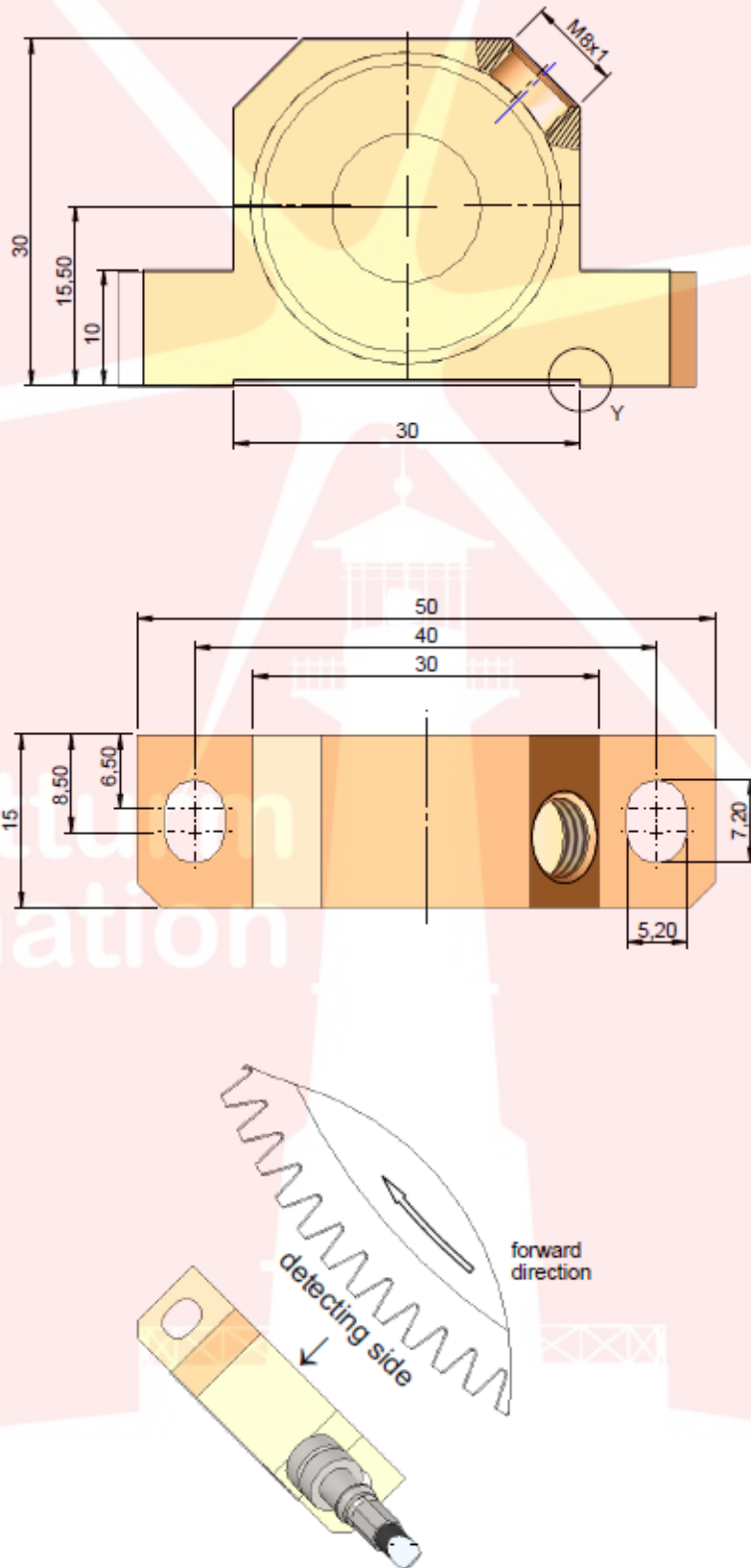



6.8 Drawing no. 8: DWG 22 - Flat housing with cable backside version

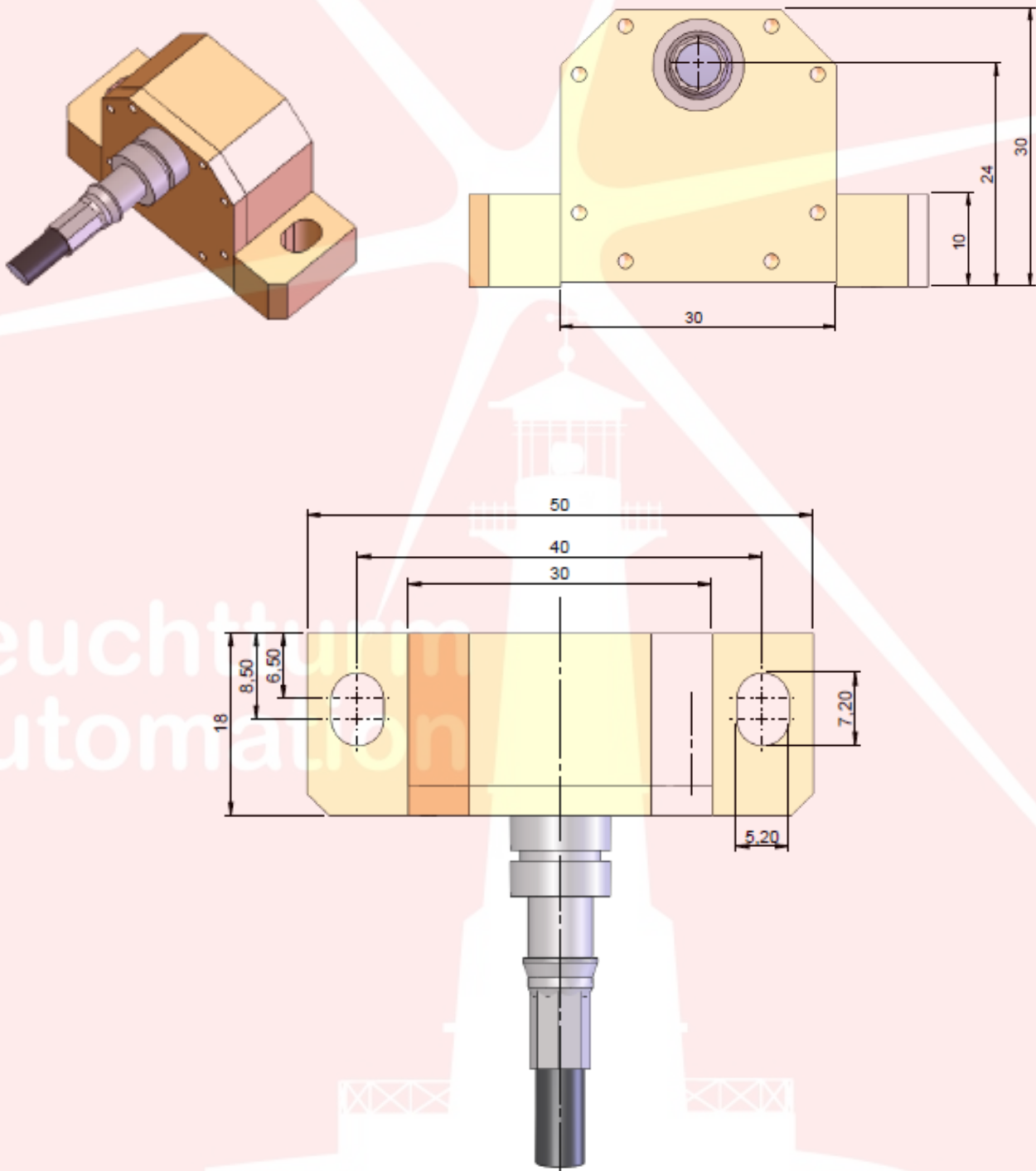



6.9 Drawing no. 9: DWG 41 - Grinding housing version

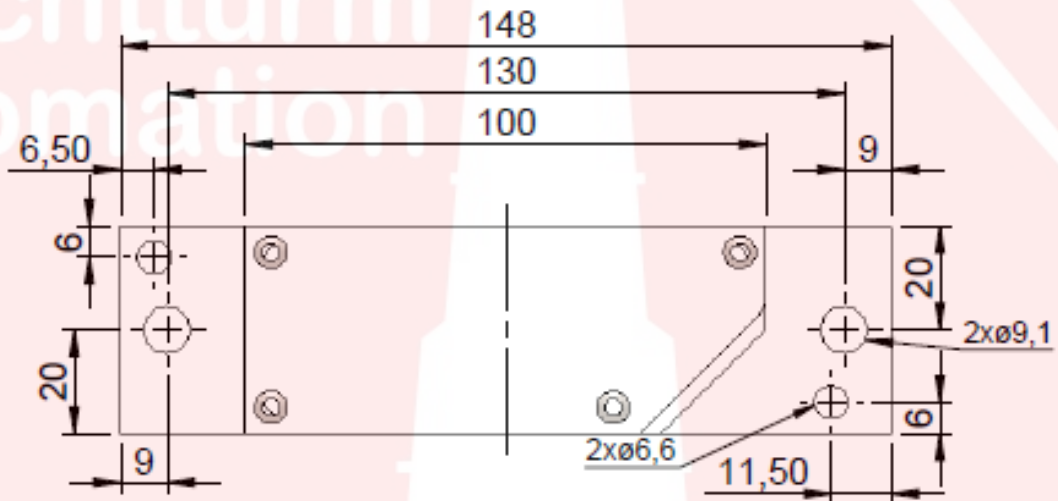
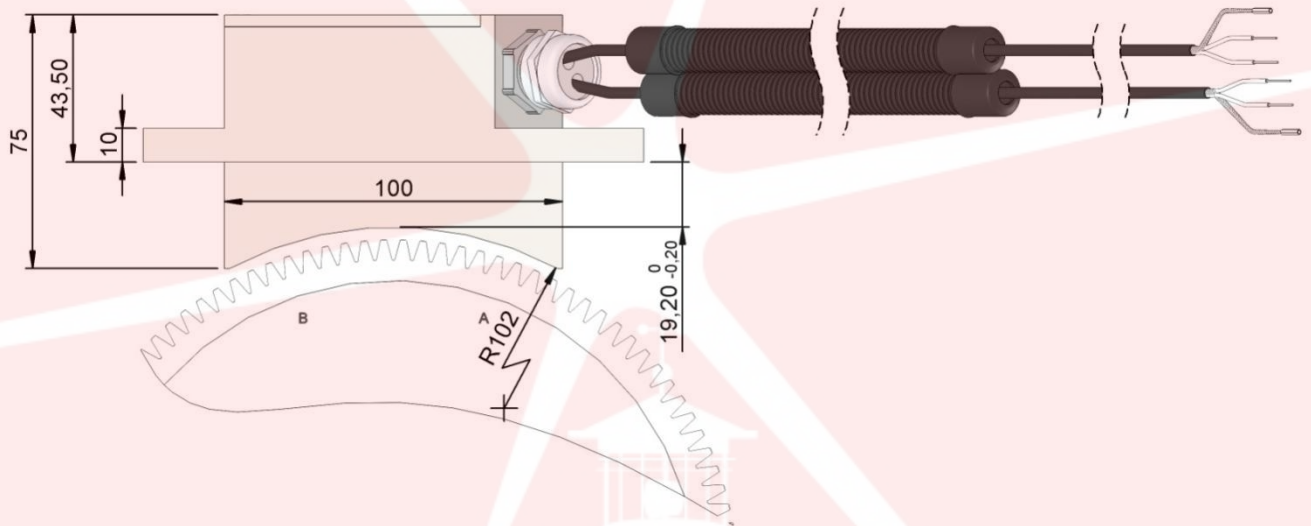



6.10 Drawing no. 10: Mounting plate for version with flange housing

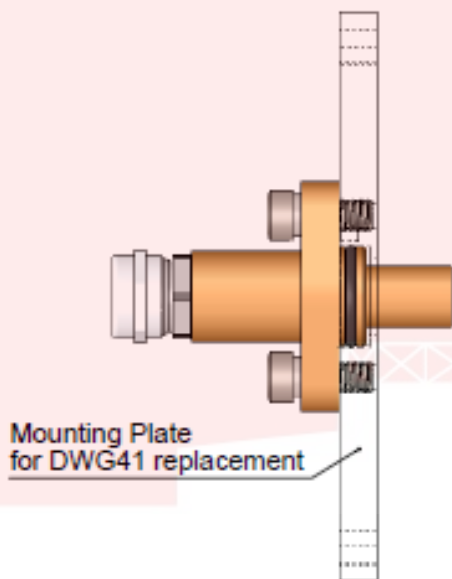
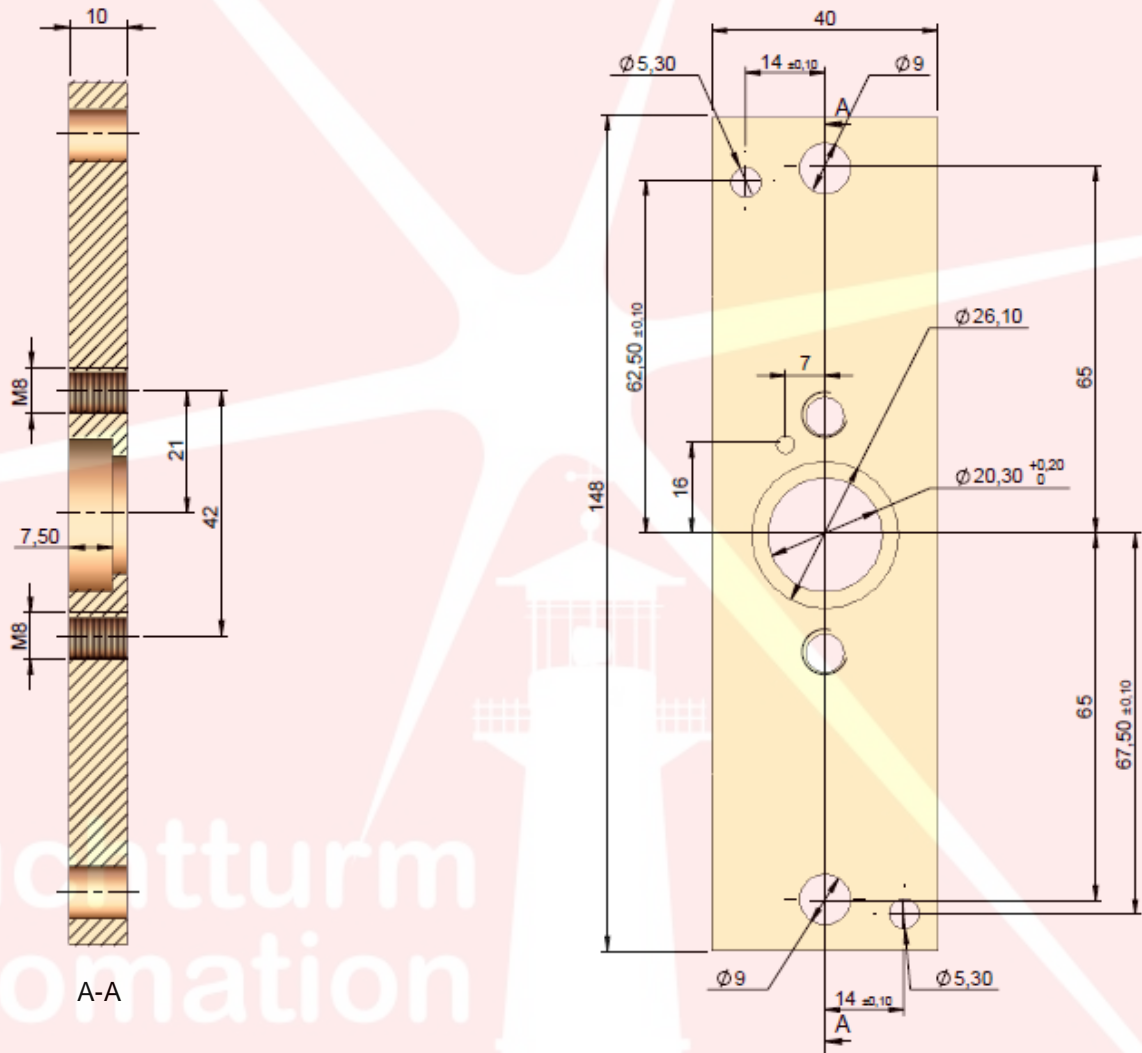



7 Structure of the match code

All EPHY-MESS speed sensors have a code name and an individual product number. The speed sensor match code includes information about housing version, electrical parameters, gear wheel type, cable length and if a plug is assembled.

The speed sensor match code consists of the following seven individual details:

DWG aa – bb – cde – nn – mmmm – z

DWG	aa	bb	c	d	e	nn	mmmm	z
			Electrical data					
Shortcut (german) for Drehwertgeber	Output signal	Housing version	Signal	Power supply	Output	Module of the gear wheel	Cable	Switchover

DWG aa – bb – cde – nn – mmmm – z

DWG	aa	Technologie
	VL	voltage
	CL	current loop

DWG aa – bb – cde – nn – mmmm – z

DWG	aa	bb	Housing version
		04	Flange housing, cable output 180°, Ø head 16 mm
		05	Flange housing, cable output 90°, Ø head 16 mm
		06	Half flange housing, cable output 180°, Ø head 16 mm
		07	Threaded sleeve type M20x1.5
		08	Asymmetrical flange, Ø head 16 mm
		09	Big flange housing, Ø head 30 mm
		14	Flange housing, cable output 180°, Ø head 24 mm
		15	Flange housing, cable output 90°, Ø head 24 mm
		21	Flat housing
		22	Flat housing, cable output backside
		41	Grinding housing



DWG aa – bb – **cde** – nn – mmmm – z

DWG	aa	bb	c	Output signal		
			T	clock signal (one channel)		
			X	2 right angle signals, 90° phase shifted		
			G	2 right angle signals, 90° phase shifted and inverse signal		
			R	clock signal+ direction signal (high/low)		
					d	Power supply
					S	single-power (one power line)
					D	dual-power (two power lines, one for each channel, no connection between both ground lines)
					H	high voltage 110 V DC (only possible in grinding housing-version 41)
						e
						Output
					X	sensor has no shifted output
					M	sensor with shifted outputs

DWG aa – bb – cde – **nn** – mmmm – z

DWG	aa	bb	cde	nn	Module of the gear wheel in 1/10 steps
				00	used for clock versions (one channel)
				10	module 1.0
				12	module 1.25
				15	module 1.5
				20	module 2.0
				25	module 2.5
				30	module 3.0

DWG aa – bb – cde – nn – **mmmm** – z

DWG	aa	bb	cde	nn	mmmm	Cable
						cable length in mm (from sensor housing end to cable end or connector). Standard cable : Sabix or Radox, shielded, wire diameter: 0.5 mm ² , shield connected to sensor housing.
					C	customized plug directly on the sensor housing

DWG aa – bb – cde – nn – mmmm – **z**

DWG	aa	bcd	nn	mmmm	z	Switchover
					CON	connector (Plug and Play)
					HP	enhanced output protection
					-	100 mm stripped cable end with end sleeves



Example: Match code

DWG aa bb cde nn mmmm z

DWG – CL – 04 – XSM – 20 – 3500 – CON

Speed sensor with flange housing, cable output 180°

2 right angle signals, 90° phase shifted

Single-Power

Module 2,0

Cable 3500 mm

Connector (Plug and Play)

Notice:

- ⚠ Speed sensor versions DWG 02 and DWG 03 are obsolete. Both versions can be replaced by version DWG 04.
- ⚠ Housing type 41 is only for using with a 120 teeth gear wheel (200 mm diameter).
- ⚠ Machines, which are equipped with speed sensors DWG 41 can be upgraded with speed sensor versions DWG 04 or DWG 05 and the installation kit.
Not suitable for 110 V DC version!
- ⚠ For speed sensors with connector we need information about connector type and pin assignment (please enclose drawing).

You didn't find the right version?

Please send us an inquiry with a drawing. Our internal sensor housing production enables a short-term realization of customized housings.



8 Questionnaire for speed sensor specification

Please answer the following questions with your customer before sending to RFQ.

Initiator and Owner:	
Company:	
Contact person:	
Address:	
Phone / Fax:	
Mail:	
Projected time line:	
Product Type:	
Estimated quantity (once, yearly):	
Price projection:	
Competing products:	

Technical Questions

1. Housing Drawing needed
2. Power Supply 8- 24 VDC 110 VDC other
3. Cable length: mm
4. Separate cable for power and signal yes no
5. Separate cable for both signal lines yes no
6. Shielded cable con. to sensor housing yes no
7. Diameter wire 0.5 mm² other: mm²
8. Cable protection yes no
9. Type of cable protection corrugated pipe rubber-textile hose
10. Connector no yes type:
11. Connector pin assignment Drawing needed
12. Number of signal lines 1 2
13. Form of signal Square wave signal 90° shifted other:
14. Gear wheel Ø 200 mm, 120 teeth yes, (air gap max 1.3 mm) no (see 16)
15. Gear wheel module M1,0 (air gap max 0.7mm) M2,0 (air gap max 1.5 mm) other: M
16. Other critical to Quality specs:

Commercial Questions

17. Delivery time for lot of
18. Price bull park 50 100 200 500



Your contact person at EPHY-MESS:

Mr. Gerhard Herdt, Sales Railway

Phone: +49 6122 9228 13

Fax: +49 6122 9228 99

Mail: gerhard.herdt@ephy-mess.de



EPHY-MESS GmbH
Berta-Cramer-Ring 1
65205 Wiesbaden
Germany

Phone: +49 6122 9228 0

Fax: +49 6122 9228 99

info@ephy-mess.de

www.ephy-mess.de

Leuchtturm Automation

EPHY MESS

Gesellschaft für Elektro-Physikalische Meßgeräte mbH



Berta-Cramer-Ring 1
D-65205 Wiesbaden
Tel.: 06122 / 9228-0
Fax: 06122 / 9228-99
www.ephy-mess.de

深圳市朝瑞自动化系统有限公司