



Leuchtturm Automation Co., Ltd.
深圳市朝瑞自动化系统有限公司



HKCFS Co., LTD.
创富世（香港）有限公司

EPHY MESS

Gesellschaft für Elektro-Physikalische Meßgeräte mbH

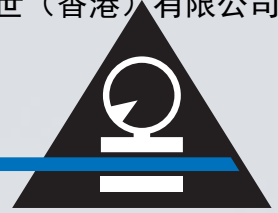

Resistance Thermometers





Contents

Notes to the use of the catalogue	2
1. Resistance Thermometer	2
1.1 Introduction	2
1.2 Overview Basic Measuring Resistors (M-XX)	3
In General	3
1.2.1 Measuring Resistor, Type (M-OK)	3
1.2.2 Measuring Resistor, Type (M-MG)	4
1.2.3 Measuring Resistor Type (M-GL)	5
1.2.4 Measuring Resistor, Type (M-KK)	6
1.2.5 Measuring Resistor Type (M-MK)	7
1.3 Cable Resistance Thermometers	8
In General	8
1.3.1 Cable Resistance Thermometer Type (M-XX/ESH/DSH)	9
1.3.2 Cable Resistance Thermometer Type (M-XX/MH)	11
1.3.3 Cable Resistance Thermometer Type (M-XX/KH)	13
1.4 Chip-Slot Resistance Thermometers	15
In General	15
1.4.1 Slot Resistance Thermometer Type (M-OK/ZS)	15
1.4.2 Slot Type Resistance Thermometer, Type (M-OK/AK)	16
1.4.2 Slot Resistance Thermometer with Plastic Housing Type (M-OK/KS)	18
1.4.3 Foil Resistance Thermometer Type (NWT-F)	19
1.5 Screw-in Resistance Thermometers	20
In General	20
Dimensions of Screw-in Thermometers with Connection Head	20
1.5.1 Screw-in Resistance Thermometer Type (M-OK/SGH)	21
1.5.2 Screw-in Resistance Thermometer Type (XESWT-Y)	23
1.5.3 Screw-in Resistance Thermometer Type (XESWT-MA)	25
1.5.4 Screw-in Resistance Thermometer Type (XESWT-EM24/38)	27
1.6 Bayonet Cap Resistance Thermometer Type XESWT-BV	29
1.7 Sheathed Resistance Thermometer (WT-MI)	31
APPENDIX	33
General guidelines for the cable confectioning	33
Clamp screw connections	33
Application temperatures of the used materials / insulations	34
Index of abbreviations	35



Notes to the use of the catalogue

Products included in this catalogue represent a general overview of the principally deliverable resistance thermometers of EPHY-MESS. In every list, different variations and modifications of one product are separated by the sign "|". Please note that the variations and modifications are not always freely combinable; for instance a socket with a small diameter requires only a specific cable or a special measuring resistor. The specification sheets are general and specify normally only the benchmark figures. Based on the countless number of possible configurations, it is impossible to present all of these variants. If you have any special requirements or desires, please contact our sales department. We also gladly develop together with you a new temperature sensor according your very special requirements.

1. Resistance Thermometer

1.1 Introduction

Resistance thermometers use a sensor, whose resistance depends upon temperature and material used – a particular change in resistance serves as a measuring unit of temperature. Resistance thermometers generally show PTC characteristics. This means, the resistance of the used sensor material increases also with the growing temperature of. This relation is approximately linear, within the framework of a certain temperature interval depending on the material. This range is very suitable for temperature measurements. For instance, platinum is a linear material within a large temperature range. Platinum has a high temperature stability and reproducibility, as well as a low tendency to wear away. However, other materials can also be used to measure temperature, such as nickel or copper. These are currently on decline, and therefore almost all the thermometers in this catalogue use platinum resistors. Other sensors, as copper or nickel are available at special occasions. Due to the above mentioned reasons, platinum thermometers have become the standard in industry today. In this catalogue the various modifications of resistance thermometers are described. Our offer ranges from basic sensors to cable thermometers, screw-in thermometers and insulated resistance thermometers.



1.2 Overview Basic Measuring Resistors (M-XX)

In General

As has been mentioned above, platinum measuring resistors according to the standard EN 60751 have become prominent in contact temperature measurement with resistance thermometers. These sensors have a rated temperature of 0°C. The rated value usually is 100 Ω. Other rated values (such as 1000 Ω) may be supplied upon request. Sensors are divided into tolerance classes AA, A and B. The following table gives overview of the maximum acceptable deviations:

Unit	Rated Value	Class AA	Class A	Class B
[Ω]	100 Ω / 0°C	± 0.04 Ω/0°C	± 0.06 Ω/0°C	± 0.12 Ω/0°C
[°C]	0°C	± 0.10°C/0°C	± 0.15°C/0°C	± 0.30°C/0°C

Tab. 1: Classification of the tolerance classes according to EN 60751 for Pt100 measuring resistors

Following the 5 at EPHY-MESS usual basic measuring resistors are described. They are the basis of all deliverable resistance thermometers.

1.2.1 Measuring Resistor, Type (M-OK)

- *Universell useable thin-film precision resistor*
- *Temperature range from -70°C ... max. +500°C*
- *Square shape, available in many different dimensions*

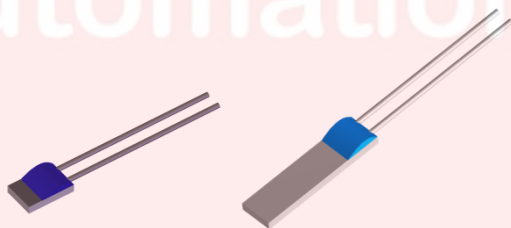

Fig. 1: Thin-layer Measuring Resistor (M-OK)

Specification	Platinum thin-layer resistor M-OK
Construction	The platinum layer is applied by means of thin-layer technology onto ceramic substrate; it is fitted with contact wires and covered with a protective layer; rectangular shape
Measuring range	-70°C... 400°C 500°C 600°C
Rated value	100 Ω 500 Ω 1000 Ω / 0°C (other rated values upon request)



Tolerance class according to EN 60751	AA A B (other tolerances upon request)
Resistance material	Platinum
Contact wires	Ag5Pd (400°C) Au5Pd (600°C), about 10 mm -15 mm long
Dimensions	from about 1.6 mm x 1.25 mm x 1 mm (length x width x thickness) (please contact our sales department for the exact dimensions)
Response time $T_{(9/10)}$ in air	from about 10 sec, according to dimensions

1.2.2 Measuring Resistor, Type (M-MG)

- *Thin-film precision resistor in a glass housing*
- *Temperature range from -50°C ... max. +500°C*
- *Mechanical protection of the thin-film sensor by a glass housing*
- *Circular shape*

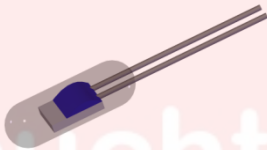

Fig. 2: Thin-layer Measuring Resistor in a glass housing (M-MG)

Specification	Platinum thin-layer resistor in a glass housing M-MG
Construction	The platinum thin-layer resistor is fitted in a glass housing; it is fitted with contact wires; rectangular shape
Measuring range	-50°C... 400°C 500°C
Rated value	100 Ω 1000 Ω / 0°C (other rated values upon request)
Tolerance class according to EN 60751	AA A B (other tolerances upon request)
Resistance material	Platinum
Contact wires	Pt/Ni, about 10 mm -15 mm long
Dimensions	from about 11.6 mm x 5 mm (please contact our sales department for the exact dimensions)



1.2.3 Measuring Resistor Type (M-GL)

- *Wire wound platinum glass resistor*
- *Temperature range from -200°C ... max. +400°C*
- *Shock resistant construction*
- *Circular shape*



Fig. 3: Wire-wound glass resistor (M-GL)

Specification	Wire-wound platinum glass resistor M-GL
Construction	<p>Model I) Platinum wire wound around a glass spindle; it is fitted with contact wires and sealed in hardened glass, cylindrical shape</p> <p>Model II) Platinum wire wound around a glass spindle; it is fitted with pull-relieved contact wires and sealed in soft glass, cylindrical shape</p>
Measuring range	-200°C ... +400°C
Rated value	1 or 2* ⁾ x 100 Ω / 0°C (other rated values upon request) *) only for Model A
Tolerance class according to EN 60751	AA A B (other tolerances upon request)
Resistance material	Platinum
Contact wires	Pt/Ni, about 10 mm -15 mm long
Dimensions	∅ from about 1.3 mm, length depends on diameter (please contact our sales department for the exact dimensions)
Response time T _(9/10) in air	from about 23 sec, according to dimensions



1.2.4 Measuring Resistor, Type (M-KK)

- *Wire wrapped platinum ceramic resistor*
- *Temperature range from -200°C ... max. +800°C*
- *Circular shape*

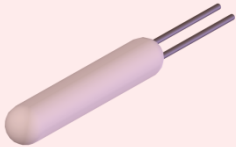

Fig. 4: Wire-wound ceramic resistor (M-KK)

Specification	Wire-wound platinum resistor with ceramic coating M-KK
Construction	Platinum wire wound around a glass spindle and insulated with ceramics; cylindrical shape
Measuring range	-200°C ... +600°C +800°C
Rated value	1 or 2 x 100 Ω / 0°C (other rated values upon request)
Tolerance class according to EN 60751	AA A B
Resistance material	Platinum
Contact wires	Pt/Ni, about 10 mm - 20 mm long
Dimensions	∅ from about 0.8 mm, length depends on diameter
Response time $T_{(9/10)}$ in air	from about 12 sec, according to dimensions



1.2.5 Measuring Resistor Type (M-MK)

- *Thin-film precision resistor in a ceramic housing*
- *Temperature range from -50°C ... max. +400°C*
- *Mechanical protection of the thin-film sensor by a ceramic housing*
- *Cylindrical shape*

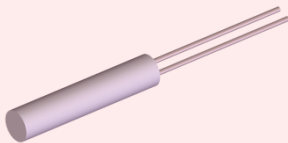

Fig. 5: Thin-film precision resistor in ceramic housing (M-MK)

Designation	Thin-film precision resistor in ceramic housing M-MK
Construction	Thin-film resistor sealed in a ceramic housing, cylindrical shape
Measuring range	-50°C... +400°C
Rated values	1 or 2 x 100 Ω / 0°C (other rated values upon request)
Tolerance class according EN 60751	AA A B
Resistance material	Platinum
Contact wires	Ni/Pt wire, about 10 mm - 20 mm long
Dimensions	From about ø2 mm, length depending on the diameter (please contact our sales department for the exact dimensions)
Response time $T_{(9/10)}$ in air	from about 20 sec, depending on the dimensions and construction



1.3 Cable Resistance Thermometers

In General

Cable resistance thermometers are frequently used and quite inexpensive solutions for various temperature measurement applications. They are mainly used to measure low and medium temperature ranges (-40°C ... 260°C). Moreover, there are even special models with an application temperature up to 400°C.

Measuring resistors Pt100 according to the standard IEC 60751 are used as basic sensors. Other rated values (500 Ω, 1000 Ω) or resistor materials (e.g. Ni, Cu) may be supplied upon request.

EPHY-MESS offers you a wide range of cable resistance thermometers. They are used mainly in these areas of application:

- Control of temperature in coil or slot of electric machines
- Measurements in laboratories and testing facilities
- Measurement of the temperature of air, water and solids
- Measurements of temperature in explosive environments

The requirements for these sensors are exceedingly manifold. For the above mentioned areas of application, e.g. also water-resistant cable thermometers for the use in liquids, as well as extra high-voltage-resistant sensors (up to 8 kV), for the direct use in high-voltage machines. Our company manufactures all temperature sensors on request of the customer. The following cable thermometers are available:

Form	Typen- bezeichnung	Cylindrical design	Groove at-shape design
ESH (single shrink hose insulated)	PR-SPA-EX-WKF	M-XX / ESH	
DSH (double shrink hose insulated)	PR-SPA-EX-WKF	M-XX / DSH	
MH (metal sleeve)	PR-SPA-EX-WKF	M-XX / MH	
KH (ceramic sleeve)	PR-SPA-EX-WKF	M-XX / KH	
AK (AK case)	PR-SPA-EX-NWT		M-OK / AK
ZS (ZS case)	PR-SPA-EX-NWT		M-OK / ZS
KS (plastic case)	PR-SPA-EX-NWT		M-OK / KS

Tab. 2: Overview of the designs of cable resistance thermometers

Type PR-SPA-EX-WKF/NWT or LTH is the classification for ATEX, IECEx and TR certified products.

For most of the above mentioned thermometers are also versions with explosive protection certification according to ATEX available.



1.3.1 Cable Resistance Thermometer Type (M-XX/ESH/DSH)

- **Cheap cable resistance thermometer for universal use**
- **Temperature range from -70°C ... max. +260°C**
- **Precision resistor crimped or soldered joined with the supply line**
- **High voltage resistant insulated, suitable for use inside the winding of electrical machines**
- **IECEX, ATEX and TR approval for the use in hazardous areas with the protection types:**

IECEX: Ex eb IIC, Ex ta IIIC, Ex ia IIC Gb, Ex ia IIIC Gb

ATEX: II 2G Ex e IIC Gb, II 2D Ex ta IIIC Da, II 2G Ex ia IIC Gb, II 2D Ex ia IIIC Db

TR: Ex ia IIC U, Ex e II U, Ex ia IIIC Db U, Ex tb IIIC Db U



Fig. 6: M-OK/ESH crimped, with PTFE insulated single wires

In General

This is a relatively simple cable thermometer, where a basic measuring resistor is assembled with a connection line and a shrinkable tubing cover. Mainly these sensors are used as sensors for the thermal protection of machines. Principally they are an inexpensive solution for all kind of temperature measurements.

Specification

Cable resistance thermometer M-XX/ESH/DSH

XX = OK | MG | GL | KK | MK |, (see Basic Measuring Resistors)

ESH = simple shrinkable tubing insulated

DSH = double shrinkable tubing insulated

Construction

Measuring resistor, one- or two-layer insulation by shrinkable tubing with a fix connected inlet

Measuring range

-70°C ... +260°C

Measuring range ATEX

-60°C ... +180°C

Temperature sensor

1 passive measuring resistor

Resistance material

Platinum

Rated resistance

100 Ω / 0°C | 1000 Ω / 0°C (other rated values upon request)

Tolerance class

AA | A | B (other tolerances upon request)

according to EN 60751

Mode of connection

2- | 3- or 4- conductor connection

Shrinkage tube insulation

- 1) ESH single-layer insulation
- 2) DSH double-layer insulation

Dimensions

∅*) from about 2**) mm, length from about 20 mm

*) round – GL, KK, MG, oval – OK

**) depends on the measuring resistor used

Material

Kynar® | Kynarfex® | PTFE



Connection line

- 1) PTFE hose conductor (Sx)
- 2) PTFE single litz wires
- 3) Teflon® flat hose line (FSx)

Cable cross-section*)

AWG 20 | 22 | 24 | 26 | 28 | 30*) SL/FLS- depends on type

Cable length

upon customer's request

Line terminal

bare conductor | tinned | cable end sleeves

Colour code

red / white, or upon customer's request

Dielectric strength

$R_{(iso)}$ 500 V \geq 200 M Ω | 1,5 kV / AC 50 Hz / 1min. |
max. 2.5 kV / AC 50 Hz / 1 min.*)

*) only with double flexible hose insulation

Special designs

water-resistant design (IP 66)

high-voltage-resistant design (up to 8 kV)

Ex e authorized design according to ATEX

Aid for product selection ESH/DSH

Characteristic	ESH	DSH
Short response time	+	
Price	+	
kV-strength	1.5 kV	2.5 kV
Mechanical solidity		+

Leuchtturm
Automation



1.3.2 Cable Resistance Thermometer Type (M-XX/MH)

- **Cable resistance thermometer with metal sleeve**
- **Temperature range from -70°C ... max. +260°C**
- **Humidity tight version possible (IP66)**
- **Multiple areas of use because of variable dimensions**
- **IECEX, ATEX and TR approval for use in hazardous areas with protection types:**

IECEX: Ex eb IIC, Ex ta IIIC, Ex ia IIC Gb, Ex ia IIIC Gb

ATEX: II 2G Ex e IIC Gb, II 2D Ex ta IIIC Da, II 2G Ex ia IIC Gb, II 2D Ex ia IIIC Db

TR: Ex ia IIC U, Ex e II U, Ex ia IIIC Db U, Ex tb IIIC Db U

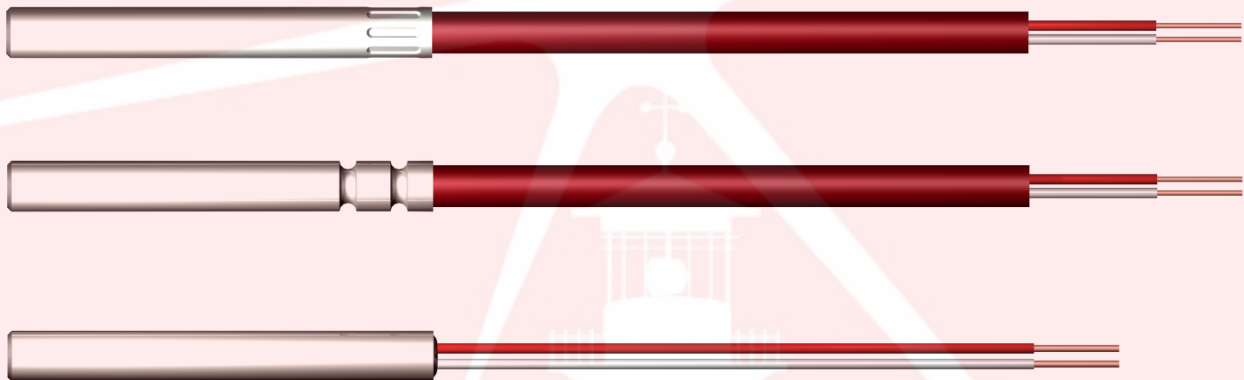

Fig. 7: Top: M-OK/MH with press bead
Middle: M-OK/MH with rolling bead
Bottom: M-OK/MH with sealing

Specification

Cable resistance thermometer with metallic capsule M-XX/MH

XX = OK | MG | GL | KK, (see Basic Measuring Resistors)

MH = metal capsule

Construction

Measuring resistor with heat-conduction paste mounted into metallic protection capsule with fix connected inlet.

Measuring range

-70°C ... +260°C

Measuring range ATEX

-60°C ... +180°C

Temperature sensor

1 or 2 passive measuring resistors

Resistance material

Platinum

Rated resistance

100 Ω / 0°C | 1000 Ω / 0°C (other rated values upon request)

Tolerance class

AA | A | B (other tolerances upon request)

according to EN 60751

Mode of connection

2- | 3- or 4- conductor connection *)

*) depending on ø of housing, number of sensors and connection line



Protection Capsule

Material	VA Ms ^{*)} <small>*) not deliverable for all dimensions</small>
Dimensions	∅ from 3 mm, step value 1 mm length from 20 mm, step value 5 mm
Cable connection	press bead rolling bead ^{*)} sealed-in <small>*) only for capsule ∅=6 mm and Si-SL</small>
Connection line	1) Teflon [®] - silicone- spun glass- hose line 2) Teflon [®] - single litz wires
Cable cross-section ^{*)}	AWG 20 22 24 26 28 30 <small>*) SL – depends on type</small>
Cable length	upon customer's request
Line terminal	bare tinned cable end sleeves
Colour code	red / white, or upon customer's request
Dielectric strength	max. 2.5 kV / AC 50 Hz / 1 min.
Assembly (optionally)	VA- clamp screw connection (see appendix)
Special designs	- screened design - water-resistant design (IP 65) <small>(only for ∅ 6 mm with silicone hose line and rolling bead)</small>

Leuchtturm
Automation



1.3.3 Cable Resistance Thermometer Type (M-XX/KH)

- **Cable resistance thermometer with ceramic sleeve**
- **Temperature range from -70°C ... max. +400°C**
- **High voltage resistant insulated, suitable for use inside the winding of electrical machines**
- **IECEX, ATEX and TR approval for use in hazardous areas with protection types:**

IECEX: Ex eb IIC, Ex ta IIIC, Ex ia IIC Gb, Ex ia IIIC Gb

ATEX: II 2G Ex e IIC Gb, II 2D Ex ta IIIC Da, II 2G Ex ia IIC Gb, II 2D Ex ia IIIC Db

TR: Ex ia IIC U, Ex e II U, Ex ia IIIC Db U, Ex tb IIIC Db U

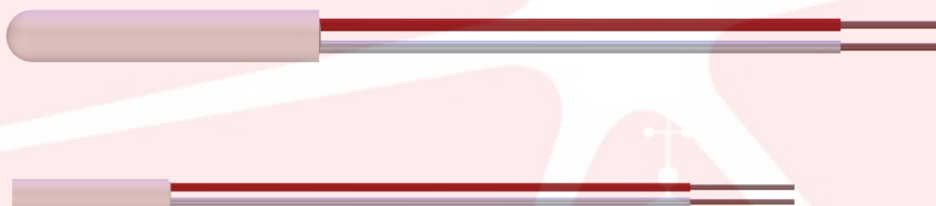

Fig. 8: M-XX/KH, 4.9 mm x 30 mm
M-XX/KH, 3 mm x 15 mm

Specification

Cable resistance thermometer with ceramic protection capsule M-XX/KH
XX = OK | MG | GL | KK, (see Basic Measuring Resistors)
KH = ceramic capsule

Construction

Measuring resistor in ceramic protection capsule sealed-in with fix connected inlet.

Measuring range

-70°C ... +260°C

Measuring range ATEX

-60°C ... +180°C

Temperature sensor

1 passive measuring resistor

Resistance material

Platinum

Rated resistance

100 Ω / 0°C | 1000 Ω / 0°C (other rated values upon request)

Tolerance class

AA | A | B (other tolerances upon request)

according to EN 60751

Mode of connection

2- | 3- or 4- conductor connection *)
*) depends on the housing and the connection line

Protection capsule

ceramic protection capsule

Material

Al₂O₃ – ceramics

Dimensions

Type	Dimensions
HÜ-KH-EFG ^{*)}	ø3 mm x 11 mm
HÜ-KH-EFG	ø3 mm x 15 mm
HÜ-KH-ERG ^{**)}	ø4.9 mm x 16 mm
HÜ-KH-ERG	ø4.9 mm x 30 mm

^{*)} EFG = single sided flat closed

^{**)} ERG = single sided round closed



Connection line

Cable cross-section*)

Cable length

Cable ends

Colour code

1) Teflon® - | spun glass- hose line

2) PTFE - single litz wires

AWG 20 | 22 | 24 | 26 | 28 | 30 *) SL – depends on type

upon customer's request

bare | tinned | cable end sleeves

red / white, or upon customer's request

Dielectric strength

max. 2.5 kV / AC 50 Hz / 1 min.

Special designs

maximum application temperature up to 400°C (only with GS-hose line)

maximum dielectric strength 5 kV, (only with Teflon® insulated supply line)

Leuchtturm
Automation



1.4 Chip-Slot Resistance Thermometers

In General

Chip-slot resistance thermometers have become an inexpensive alternative to the bifilar coiled slot resistance thermometers (medium value sensors). At these types, a platinum thin-layer measuring resistor M-OK is used instead of a bifilar coiled platinum cable. The active measuring length is shortened to the active measuring length of the thin-layer sensor (point measurement). For most measurement applications this is completely sufficient, because the requirements mostly refer to the design (groove) and not to the active measuring length. Slot type resistance thermometers (NWT) offered by EPHY-MESS are mainly used in the grooves of the stator coiling of electric machines. Therefore, all the variations are also deliverable in an ex-certificated version according to ATEX. Principally these thermometers can be used also for all other kinds of measurements on surfaces, in grooves or on other hardly accessible measuring locations.

1.4.1 Slot Resistance Thermometer Type (M-OK/ZS)

- **Measuring resistor sealed into an Epoxyd inter-slider (ZS)**
- **Temperature range from -65°C ... max. +200°C**
- **For mounting direct in the slots of electrical motors/generators**
- **Adjustable to almost each slot dimension**
- **IECEX, ATEX and TR approval for use in hazardous areas with protection types:**

IECEX: Ex eb IIC, Ex ta IIIC, Ex ia IIC Gb, Ex ia IIIC Gb

ATEX: II 2G Ex e IIC Gb, II 2D Ex ta IIIC Da, II 2G Ex ia IIC Gb, II 2D Ex ia IIIC Db

TR: Ex e II U, Ex tb IIIC Db U, Ex ia IIC U, Ex ia IIIC Db U

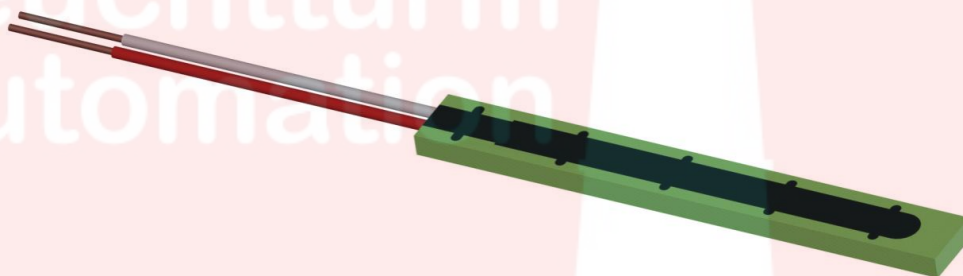

Fig. 9: M-OK/ZS in 2-wire line connection with ribbon cable hose line

Specification	Slot type resistance thermometer, inter-slider M-OK/ZS ZS = inter-slider
Construction	Pt-thin-layer measuring resistor with fix connected inlet, fixed by bridges and directly sealed into epoxy inter-slider housing
Measuring range	-65°C ... +200°C
Measuring range ATEX	-60°C ... +180°C



Temperature sensor

Rated resistance	passive Pt-thin-film measuring resistor, active measuring length about 2 mm
Mode of connection	100 Ω / 0°C 1000 Ω / 0°C, (other rated values upon request)
Tolerance class according to EN 60751	2- 3-*) or 4-*) conductor connection *) depends on the line cross-section and on the width of the part
	AA A B (other tolerances on request)

Housing

Material	Epoxy inter-slider, non-flexible
Dimensions (min.)	epoxy resin thick _(min.) = 2 mm x width _(min.) = 8 mm x length _(min.) = 20 mm

Standard dimensions

thick [mm]	width [mm]	length [mm]
3	8	100
3	8	50
2	10	60
2	10	100
2	8	100
2	8	65
2	8	30

Connection line

Colour code	PTFE – single litz wires ribbon cable hose line red / white, or upon customer's request
Cable cross-section	AWG20 AWG24 AWG26 AWG28; FSL - depends on type
Cable length	upon customer's request
Cable ends	bare tinned cable end sleeves

Dielectric strength

max. 2.5 kV / AC 50 Hz / 1 min.

Special designs

Ex - approved versions

1.4.2 Slot Type Resistance Thermometer, Type (M-OK/AK)

- **Measuring resistor pressure free sealed into a housing (AK)**
- **Temperature range from -65°C ... max. +200°C**
- **For mounting direct in the slots of electrical motors/generators**
- **Adjustable to almost each slot dimension**
- **IECEX, ATEX and TR approval for use in hazardous areas with protection types:**

IECEX: Ex eb IIC, Ex ta IIIC, Ex ia IIC Gb, Ex ia IIIC Gb

ATEX: II 2G Ex e IIC Gb, II 2D Ex ta IIIC Da, II 2G Ex ia IIC Gb, II 2D Ex ia IIIC Db

TR: Ex e II U, Ex tb IIIC Db U, Ex ia IIC U, Ex ia IIIC Db U

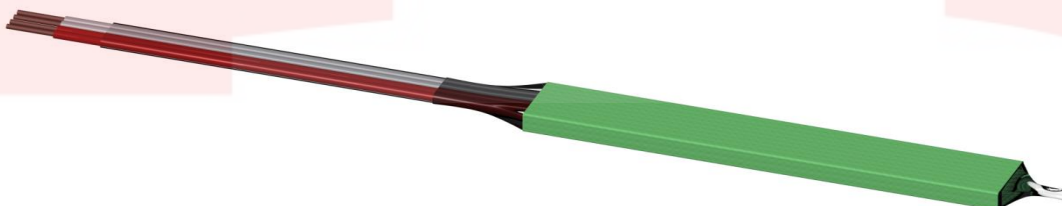

Fig. 10: M-OK/AK with 4-wire connection and flat hose line



Specification	Slot type resistance thermometer, housing M-OK/AK AK = Housing															
Construction	Mounted and sealed Pt-thin-layer measuring resistor in HGW housing with a cover plate. Insulated by PTFE shrinkable tubing and fix connected inlet.															
Measuring range	-65°C ... +200°C															
Measuring range ATEX	-60°C ... +180°C															
Temperature sensor	1 passive Pt-thin film measuring resistor, active measuring length about 2 mm															
Rated resistance	100 Ω / 0°C 1000 Ω / 0°C (other rated values upon request)															
Mode of connection	2- 3-*) or 4-*) conductor connection *) depends on the line cross-section and on the width of the part															
Tolerance class according to EN 60751	AA A B (other tolerances upon request)															
Housing	HGW Housing, slight flexible															
Material	silicone glass fabric base laminate															
Dimensions (min.)	thick _(min.) = 2 ^{±0,3} width _(min.) = 5 ^{±0,3} mm length _(min.) = 15 ^{±0,5} mm															
Standard dimensions																
	<table border="1"> <thead> <tr> <th>thick [mm]</th> <th>width [mm]</th> <th>length [mm]</th> </tr> </thead> <tbody> <tr> <td>2</td> <td>6</td> <td>63</td> </tr> <tr> <td>2</td> <td>10</td> <td>65</td> </tr> <tr> <td>2</td> <td>8</td> <td>63</td> </tr> <tr> <td>3</td> <td>8</td> <td>100</td> </tr> </tbody> </table>	thick [mm]	width [mm]	length [mm]	2	6	63	2	10	65	2	8	63	3	8	100
thick [mm]	width [mm]	length [mm]														
2	6	63														
2	10	65														
2	8	63														
3	8	100														
Connection line	PTFE-single litz wires PTFE ribbon cable hose line (FSL)															
Colour code	red / white, or upon customer's request															
Cable cross-section	AWG20 AWG24 AWG26 AWG28; FSL - depends on type															
Cable length	upon customer's request															
Cable ends	bare tinned cable end sleeves															
Dielectric strength	max. 3 kV / AC 50 Hz / 1 min.															
Special designs	- Ex e / Ex i authorized version - Dielectric strength up to 5 kV															



1.4.2 Slot Resistance Thermometer with Plastic Housing Type (M-OK/KS)

- **Measuring resistor sealed in a plastic housing (KS)**
- **Temperature range from -60°C ... max. +180°C**
- **For direct mounting in the slots of electrical motors / generators**
- **IECEX, ATEX and TR approval for use in hazardous areas with protection types:**

IECEX: Ex eb IIC, Ex ta IIIC, Ex ia IIC Gb, Ex ia IIIC Gb

ATEX: II 2G Ex e IIC Gb, II 2D Ex ta IIIC Da, II 2G Ex ia IIC Gb, II 2D Ex ia IIIC Db

TR: Ex e II U, Ex tb IIIC Db U, Ex ia IIC U, Ex ia IIIC Db U



Fig. 11: M-OK/KS with PTFE single litz wires

Specification	Slot resistance thermometer, plastic housing M-OK/KS*) *) KS = plastic housing									
Construction	Pt-thin-layer measuring resistor, sealed in plastic housing (moulded), with fix connected inlet									
Measuring range	-60°C ... +180°C									
Measuring range ATEX	-60°C ... +180°C									
Temperature sensor	1 passive thin-layer measuring resistor, active measuring length about 2 mm									
Resistance material	Platinum									
Rated resistance	100 Ω / 0°C 1000 Ω / 0°C (other rated values upon request)									
Mode of connection	2- 3- conductor connection									
Tolerance class according to EN 60751	AA A B (other tolerances upon request)									
Housing	plastic moulded housing, sealed, stiff									
Dimensions	<table border="1"> <thead> <tr> <th>thick [mm]</th> <th>width [mm]</th> <th>length [mm]</th> </tr> </thead> <tbody> <tr> <td>2</td> <td>8</td> <td>100</td> </tr> <tr> <td>2</td> <td>10</td> <td>65</td> </tr> </tbody> </table>	thick [mm]	width [mm]	length [mm]	2	8	100	2	10	65
thick [mm]	width [mm]	length [mm]								
2	8	100								
2	10	65								
Connection line	PTFE-single litz wires PTFE-ribbon cable hose line									
Colour code	red / white, or upon customer's request									
Cable cross-section	AGW24*) AWG26 AWG28 *) not with the 3-wire connection									
Cable length	upon customer's request									
Cable ends	bare conductor tinned cable end sleeve									
Dielectric strength	max. 2.5 kV / AC 50 Hz / 1 min.									



1.4.3 Foil Resistance Thermometer Type (NWT-F)

- *Platinum resistance wire between a Kapton foil*
- *Temperature range from -60°C ... max. +200°C*
- *Flexible, very thin construction*
- *On request also available with a glue layer*
- *Short response time*
- *Easy assembly*

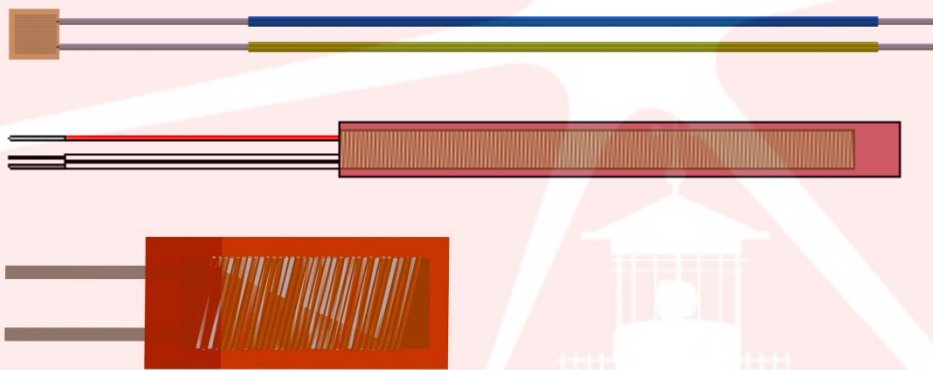

Fig.:12: Top: NWT-form A
Middle: NWT-form B
Below: NWT-F form C

Construction:

The Pt100 foil thermometers consist of a wrapped platinum wire between a Kapton foil. For some versions, the foil is also available with an adhesive tape on the back. Wire length and connection type (2-, 3- or 4-wire) are build regarding customer demand.

Areas of use:

Foil resistance thermometers are recommended for measurement on small and inaccessible places and on flat or slightly curved surfaces. Furthermore it is also suitable for the measurement on surfaces of pipes (surface thermometer).

Technical specification Pt100:

Dimension	Connection line	Nominal value / tolerance	Insulation	Response time $T_{0.63}$ in H ₂ O	Tmax	Form
7.6 x 7.6 x 0.7 mm ^{*)}	2x AWG28 600 mm	100 Ω/± 0.12 Ω	Kapton	0.15s	200°C	A
7.6 x 7.6 x 0.7 mm ^{*)}	4x AWG28 600 mm	100 Ω/± 0.12 Ω	Kapton	0.15s	200°C	A
101 x 9.5 x 1.7 mm	3x AWG26 900 mm	100 Ω/± 0.12 Ω	Kapton	0.20s	200°C	B
50 x 21 x 0.2 mm	Flat line, blank	100 Ω/± 0.12 Ω	Kapton	T _{0.5} < 3s	200°C	C

^{*)} optional with adhesive tape on the backside



1.5 Screws-in Resistance Thermometers

In General

The group of screw-in resistance thermometers includes the various thermometers with fix screw connection or shiftable clamping screw connection. They are deliverable with or without connection head. The group of screw-in thermometers with fix connected inlet includes the relatively small thermometers of the M-OK/SGH series. They are often used in narrow spaces, as well as on front surfaces of machine cases and for control of surface temperatures, e.g. in switchboards. At this construction a basic sensor with fix connected inlet is sealed in screw housing.

The group of the compact screw-in thermometers with connection head includes the thermometers of the type EM24. They are often used for control of the bearing temperature of electric motors and generators and for this they are also deliverable in a certified Ex-version according to IECEx, ATEX and TR (ignition protection system, type Ex i resp. Ex e).

In chemical industry and plant engineering, mainly the large screw-in thermometers with DIN connection head form A or B are used. These are deliverable in various constructions, e.g. with an exchangeable measuring insert or with MI insulated protection tubes and application temperatures up to 600°C.

Dimensions of Screw-in Thermometers with Connection Head

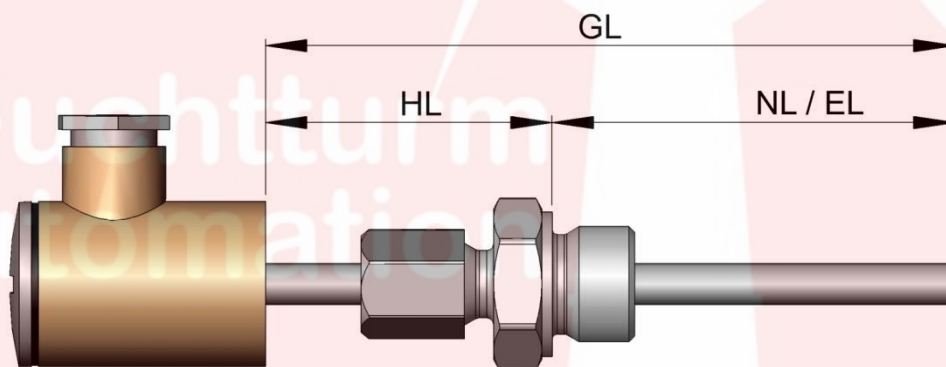

Fig. 13: Relevant dimensions of screw-in thermometers with connection head

Neck tube length (HL)

=> length from the bottom edge of the head to the seal

Installation length / Nominal length (EL/NL)

=> length from the seal to the bottom edge of the protection tube

Total length (GL)

=> length from the bottom edge of the protection tube to the bottom edge of the connection head



1.5.1 Screw-in Resistance Thermometer Type (M-OK/SGH)

- **Measuring sensor sealed in a screw-housing**
- **Temperature range from 40°C ... max. +260°C**
- **Easy assembly, suitable to screw in housings and surfaces**
- **Different screws made of messing, aluminium or stainless steel**
- **Selectively with fix supply line or connection plug**
- **IECEX, ATEX and TR approval for use in hazardous areas with protection types:**

IECEX: Ex eb IIC, Ex ta IIIC, Ex ia IIC Gb, Ex ia IIIC Gb

ATEX: II 2G Ex e IIC Gb, II 2D Ex ta IIIC Da, II 2G Ex ia IIC Gb, II 2D Ex ia IIIC Db

TR: Ex e II U, Ex tb IIIC Db U, Ex ia IIIC Db U

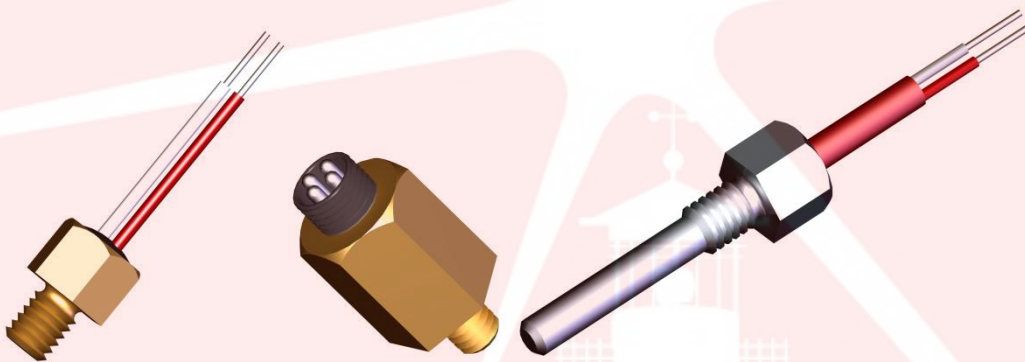

Fig. 14: Left: M-OK/SGH type A (without protection tube) screw-in housing made of brass with PTFE-single braid wires
 Middle: M-OK/SGH type A (without protection tube) screw-in housing with sealed connection plug
 Right: M-OK/SGH type B (with protection tube) stainless steel housing with fix connected hose line.

Specification	Screw-in resistance thermometer, screw housing (M-OK/SGH), model A or B
Construction	<p>Model: (A) measuring resistor sealed in a brass or aluminium housing, with fix connected inlet</p> <p>Model: (B) measuring resistor sealed in VA – capsule with fix screw connection and connected inlet</p>
Measuring range	-40°C ... +260°C
Measuring range ATEX	-60°C ... +180°C
Temperature sensor	1 passive measuring resistor
Resistance material	Platinum
Rated resistance ¹⁾	100 Ω / 0°C 1000 Ω / 0°C (other rated values upon request)
Tolerance class according to EN 60751	AA A B (other tolerances upon request)
Mode of connection	2- 3-*) or 4-*) conductor connection *) depending on the size of SGH



Screw housing for model (A)

material	thread x mounting length	SW x height
brass	M4 x 7.5 mm	SW 7x10 mm
brass	M4 x 6.0 mm	SW 7x10 mm
brass	M5 x 7.5 mm	SW 8x10 mm
brass	M6 x 7.5 mm*	SW 10x10 mm
brass	M6 x 7.5 mm*	SW 8x15 mm
brass	M8 x 8.0 mm*	SW 19x24 mm**
brass	M8 x 7.5 mm*	SW 13x10 mm
aluminium	M4 x 6.0 mm	SW 8x8 mm
aluminium	M5 x 6.0 mm	SW 8x12 mm

* sensor in the screw base

**with fix sealed connection sleeve (4-pole) see Fig. 13) Middle

VA-capsules and screw connections for model (B)

Ø-VA-capsule [mm]	EL [mm]	VA-VSB
4 mm	from 20	M10x1
5 mm		G1/4"
6 mm (standard)		G1/2"
8 mm		

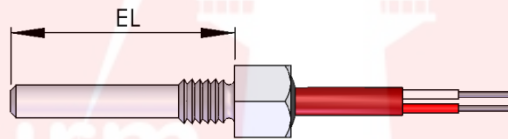

Input

Cable length

Cable ends

Colour code

Dielectric strength

1) PTFE- or spun glass hose line^{*)}

^{*)} hose line depends on the size of the screw housing

2) PTFE – single litz wires

upon customer's request

bare | tinned | cable end sleeves

red / white, or upon customer's request

$R_{(ISO)} 500V \geq 200 M\Omega$ | max. 2 kV / AC 50 Hz / 1 min.^{*)}

^{*)} not at spun glass line



1.5.2 Screw-in Resistance Thermometer Type (LTH-Y)

- **Screw-in thermometer with connection head form B**
- **Temperature range from -70°C ... max. +600°C**
- **Robust construction for the use in rough industrial environments**
- **Electively with fix or changeable measuring insert**
- **Optional with head transmitter**
- **IECEX, ATEX und TR approval for the use in hazardous areas with protection types:**

IECEX: Ex e IIC T6...T3 Gb, Ex ta IIIC T80°C/T95°C/T130°C/T180°C Db

Ex ia IIC T6...T3 Gb, Ex ia IIIC T80°C/T95°C/T130°C/T180°C Db

ATEX: II 2G Exe IIC T6...T3 Gb, II 2D Ex ta IIIC T80°C/T95°C/T130°C/T180°C Da

II2G Ex ia IIC T6...T3 Gb, II 2D Ex ia IIIC T80°C/T95°C/T130°C/T180°C D

TR: 2 Ex e II T6 ... T3 Gb, Ex tb IIIC T80°C/T95°C/T130°C/T180°C Db

1 Ex ia IIC T6 ... T3 Gb, Ex ia IIIC T80°C/T95°C/T130°C/T180°C Db

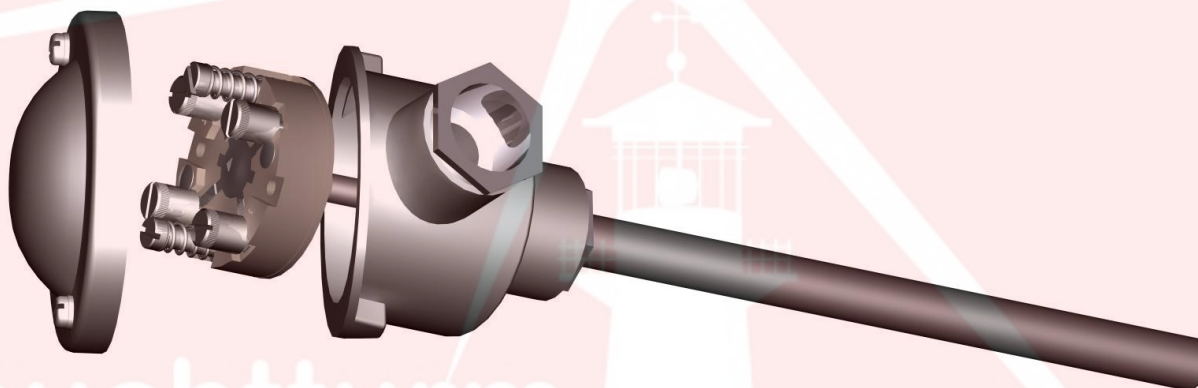

Fig. 15: LTH-B with DIN head form B, and exchangeable measuring insert in a 4-wire connection

Specification	Screw-in resistance thermometer with DIN connection head (X)LTH-Y X = E for single-sensor / X = D for double-sensor Y = A for head form A / Y = B for head form B
Construction	VA-protection tube with optional fix mounted measuring resistor or exchangeable measuring insert and DIN connection head form A or B
Measuring range	-70°C ... +600°C
Measuring range ATEX	-60°C ... +180°C
Temperature sensor	1 or 2 passive measuring resistors fix mounted 1 or 2 passive measuring resistors with exchangeable measuring insert
Resistance material	Platinum
Rated resistance	100 Ω / 0°C 1000 Ω / 0°C (other rated values upon request)
Tolerance class according to EN 60751	AA A B (other tolerances upon request)
Mode of connection	2- 3- or 4-conductor connection
Connection head	form A form B
Material	aluminium
Interior construction	ceramic clamp socket, 2 / 3 / 4 / 6 / 8 -pole
Cable outlet	PG16



Protection tube

- 1) with measuring resistor insulated by shrinkable tubing
- 2) with minerally insulated measuring resistor
- 3) with exchangeable measuring insert and fix connected clamp socket

Material

VA-steel

Dimensions

∅ 9 mm | 11 mm, other ∅ upon request, GL from 50 mm

Neck tube length

0*) | 30 mm | 40 mm other stem lengths upon request

*) only with a fixed screwing neck

Rated length

from 20 mm to 1000 mm, longer upon request

Dielectric strength

$R_{(iso)}$ 500V ≥ 200 MΩ | max. 2.5 kV / AC 50 Hz / 1 min.

Assembly

1) VA-clamp screw connection, fix or shiftable^{*)}, with Teflon or steel clamping ring^{*)} only with PTFE-clamping ring

2) VA-screw-in adapter, fix

thread for 1), 2): M10x1 | G1/4" | G3/8" | G1/2" | G3/4" | G1"

Accessories

silicone- and Teflon[®]-hose line pre-assembled upon customer's request
Optional with head transmitter 4-10 V or 4-20 mA

Leuchtturm Automation



1.5.3 Screw-in Resistance Thermometer Type (LTH-MA)

- **Screw-in thermometer with connection head form MA**
- **Temperature range from -70°C ... max. +260°C**
- **Electively with fix or shiftable screw connection**
- **Optional with head transmitter (4-20mA)**
- **IECEX, ATEX und TR approval for the use in hazardous areas with protection types:**

IECEX: Ex e IIC T6...T3 Gb, Ex ta IIIC T80°C/T95°C/T130°C/T180°C Db
Ex ia IIC T6...T3 Gb, Ex ia IIIC T80°C/T95°C/T130°C/T180°C Db

ATEX: II 2G Exe IIC T6...T3 Gb, II 2D Ex ta IIIC T80°C/T95°C/T130°C/T180°C Da
II2G Ex ia IIC T6...T3 Gb, II 2D Ex ia IIIC T80°C/T95°C/T130°C/T180°C D

TR: 2 Ex e II T6 ... T3 Gb, Ex tb IIIC T80°C/T95°C/T130°C/T180°C Db
1 Ex ia IIC T6 ... T3 Gb, Ex ia IIIC T80°C/T95°C/T130°C/T180°C Db

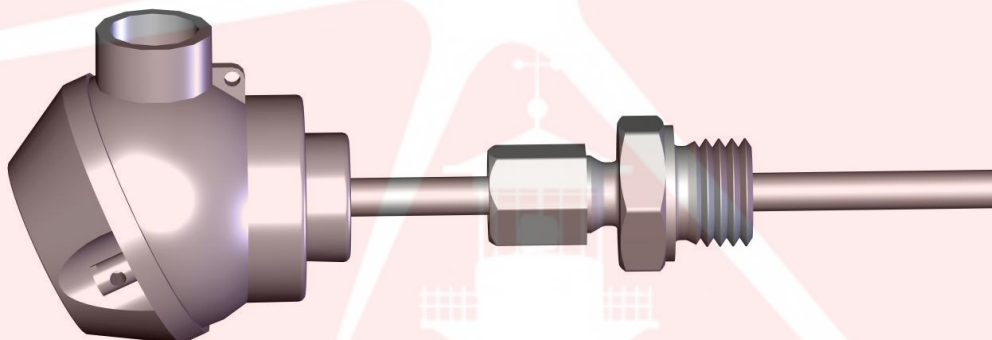

Fig. 16: Screw-in Resistance Thermometer LTH-MA with shiftable screw connection

Specification

Screw-in resistance thermometer with MA-head (X)LTH-MA

X = E for single-sensor

X = D for double-sensor

Construction

VA-protection tube with fix mounted measuring resistor and connection head type MA, optionally with or without connection line. Fix or shiftable screw connection optionally available as accessory

Measuring range

-70°C ... +260°C

Measuring range ATEX

-60°C ... +180°C

Temperature sensor

1 or 2 passive measuring resistors fix mounted

Resistance material

Platinum

Rated resistance

100 Ω / 0°C | 1000 Ω / 0°C (other rated values upon request)

Tolerance class

AA | A | B (other tolerances upon request)

according to EN 60751

Mode of connection¹⁾

2- | 3-*) and 4-*) conductor connection

*) not with double measuring resistor

Connection head

form MA with cover

Material

aluminium

Interior construction

ceramic clamp socket, 2 / 4 -pole

Cable outlet

PG9

IP-Protection class

54



Protection Tube

Material

with measuring resistor insulated by shrinkable tubing

VA-steel

Dimensions

ø 6 mm | 8 mm, other ø upon request, GL from 50 mm

Neck tube length

0 | 30 mm | 40 mm; other stem lengths upon request

Rated length

from 20 mm to 1000 mm, longer rated lengths upon request

Dielectric strength

$R_{(iso)} 500V \geq 200 M\Omega$ | max. 2,5 kV / AC 50 Hz / 1 min.

Assembly

(optional)

1) VA-clamp screw connection, fix or shiftable clamping ring:

PTFE | steel

2) VA-screw-in adapter fix

thread for 1),2): M10x1 | G1/4" | G3/8" | G1/2" | G3/4" | G1"

Accessories

silicone and PTFE-hose line pre-assembled upon customer's request or already connected

Leuchtturm
Automation



1.5.4 Screw-in Resistance Thermometer Type (LTH-EM24/38)

- **Screw-in thermometer with connection head form EM24/38**
- **Temperature range from -70°C ... max. +260°C**
- **Compact connection head, electively with clamping socket or fix sealed supply line**
- **Optional with head transmitter (4-20mA)**
- **IECEX ,ATEX and TR approval for use in hazardous areas with protection types:**

IECEX: Ex e IIC T6...T3 Gb, Ex ta IIIC T80°C/T95°C/T130°C/T180°C Db

Ex ia IIC T6...T3 Gb, Ex ia IIIC T80°C/T95°C/T130°C/T180°C Db

ATEX: II 2G Exe IIC T6...T3 Gb, II 2D Ex ta IIIC T80°C/T95°C/T130°C/T180°C Da

II2G Ex ia IIC T6...T3 Gb, II 2D Ex ia IIIC T80°C/T95°C/T130°C/T180°C D

TR: 2 Ex e II T6 ... T3 Gb, Ex tb IIIC T80°C/T95°C/T130°C/T180°C Db

1 Ex ia IIC T6 ... T3 Gb, Ex ia IIIC T80°C/T95°C/T130°C/T180°C Db

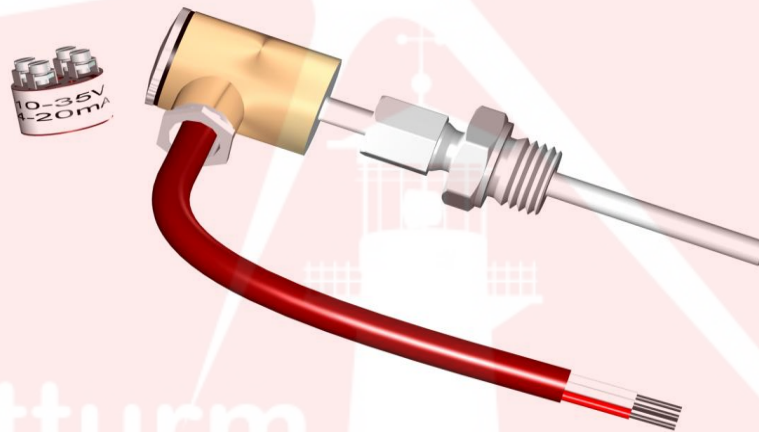

Fig. 17: Screw-in Thermometer DESWT-EM24, brass bare, VA-protection tube, PG9 cable gland, shiftable VSB. Optionally also with head transmitter (4-20mA)

Specification	Screw-in resistance thermometer with EM24/38 head (X)LT-EM24/38 X = E for single-sensor / X = D for double-sensor 24 = connection head EM24 / 38 = connection head EM38
Construction	Measuring resistor insulated mounted into a VA-protection tube with fix connection head type EM24 or EM38, optionally with or without connection line. Fix or shiftable screw connection optionally available as accessory
Measuring range	-70°C ... +260°C
Measuring range ATEX	-60°C ... +180°C
Temperature sensor	1 or 2 passive resistance sensors (thin-layer or wire coiled, M-OK / M-MK / M-GL / M-KK)
Material	Platinum
Rated resistance	100 Ω / 0°C 1000 Ω / 0°C (other rated values upon request)
Tolerance class according to EN 60751	AA A B (other tolerances upon request)
Mode of connection¹⁾	2- 3-*) and 4-*) conductor connection *) 3- and 4-conductor connection - not with double sensor and EM24 head



Connection head	EM24 + cover EM38 + cover
Material	brass bare brass – nickel-coated
Dimensions	EM24: ø24 mm, height approx. 31 mm EM38: ø38 mm, height approx. 33 mm
Interior construction	clamp socket sealed
Cable outlet	PG9*) PG11*) PG with additional traction relief Opel-VSB sealed *) upon request with additional traction relief
Protection tube	VA, bare insulated by shrinkable tubing *)
	*) max. protection tube temperature is reduced to 120°C at Elastomer
Dimensions	ø 6 8 mm, total length from 50 mm (other ø upon request)
Neck tube length	30 mm 40 mm
Rated length	from 20 mm - 1000 mm, longer rated lengths upon request
Input	with or without hose line
Insulation	Silicone PTFE*) *) only upon explicit customer's request
Colour code	red / white, or upon customer's request
Cable cross-section	AWG20 AWG24
Cable connection	fixed (sealed) clamped no connection
Dielectric strength	$R_{(iso)} 500V \geq 200 M\Omega$ max. 2.5 kV / AC 50 Hz / 1 min.
Assembly	1) VA- fitting, fix or shiftable ^{*)} , clamping ring: PTFE / steel *) only with PTFE-clamping ring 2) VA-screw-in adapter, fix thread for 1),2): M10x1 G1/4" G3/8" G1/2" G3/4" G1"
On request	- with head transmitter 4-20mA

Connector plan

EM24 head

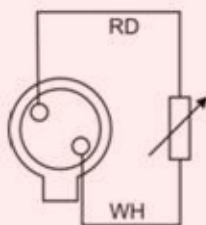

1x2w

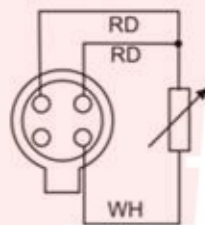

1x3w

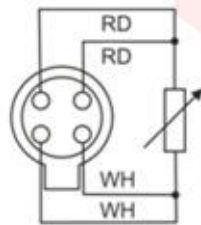

1x4w

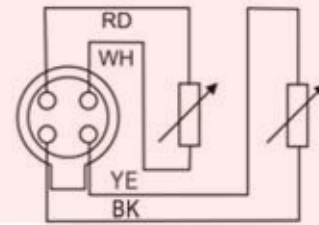

2x2w

RD = red BK = black
WH = white YE = yellow
w = wires



1.6 Bayonet Cap Resistance Thermometer Type LTH-BV

- **Plug-in thermometer with bayonet lock**
- **Temperature range from -70°C ... max. +260°C**
- **Easy and quick assembly / disassembly**
- **Especially suitable for monitoring the bearing temperature of electrical motors**
- **IECEX, ATEX and TR approval for use in hazardous areas with protection types:**

IECEX: Ex eb IIC, Ex ta IIIC, Ex ia IIC Gb, Ex ia IIIC Gb

ATEX: II 2G Ex e IIC Gb, II 2D Ex ta IIIC Da, II 2G Ex ia IIC Gb, II 2D Ex ia IIIC Db

TR: Ex e II U, Ex tb IIIC Db U, Ex ia IIIC Db U

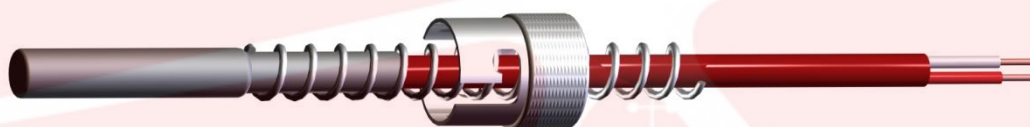

Fig. 18: Bayonet Cap Resistance Thermometer in 4-wire connection, front surface of the protection housing is flat closed

Specification

Jay-Slot Thermometer (X)LTH-BV

X = E for single-sensor

X = D for double-sensor

BV = jay-slot

Construction

Measuring resistor insulated mounted into a VA-housing with fix connected hose line. Tension spring mounted on adapter with shiftable jay-slot hood for adjustment of the required pre-tension.

Measuring range

-70°C ... +260°C

Measuring range ATEX

-60°C ... +180°C

Temperature sensor

1 or 2 Pt thin-layer measuring resistors

Rated resistance

100 Ω / 0°C | 1000 Ω / 0°C

Tolerance class

according to EN 60751

AA | A | B (other tolerances upon request)

Mode of connection

2- | 3-*) and 4-*) conductor connection

*) 3- and 4-conductor connection - not with double sensor

Protection capsule

VA-capsule, ø6xNL=47/GL=60, beveled,
front surface: flat closed | drill angle 118°

Dimensions

ø6xNL=47/GL=60

Cable outlet

fix, capsule beaded

Assembly

jay-slot cover VA 1.4305, ø=14 mm | 12.4, length = 24 mm adjustable upon pressure spring

Spring length

175 mm | 210 mm | 250 mm



Connection line

Cover

Cable length

Cross-section

Conductors

Colour code

screened PTFE-hose line

inside | outside | laid up

from 170 mm

0.23 mm²

bare / tinned / end sleeves

according to EN 60751, or upon customer's request

Dielectric strength

$R_{(iso)}$ 500V \geq 200 M Ω | max. 2 kV / AC 50 Hz / 1 min.

Accessories

screw-in nipples \varnothing 12/7 mm, Ms nickel-plated M10x1 SW14 length = 60 mm

screw-in nipples \varnothing 12/7 mm, Ms nickel-plated M10x1 SW14 length = 30 mm

Leuchtturm
Automation



1.7 Sheathed Resistance Thermometer (WT-MI)

- **Sheathed resistance thermometer with flexible mineral insulated-line**
- **Temperature range from -200°C ... max. +800°C**
- **Mineral insulated line diameter from 1 mm possible**
- **Water tight (IP68)**



Fig. 19: Sheathed resistance thermometer with cable junction capsule and fix connected line

Specification	WT-MI, Sheathed resistance thermometer MI = mineral insulated WT= resistance thermometer
Construction	Measuring resistor, mineral insulated mounted into a VA-capsule, welded with mineral insulated sheathed line and different types of connections.
Measuring range	-200°C ... +500°C +600°C
Temperature sensor	1 or 2 Pt-measuring resistors, wire coiled
Rated resistance	100 Ω / 0°C 1000 Ω / 0°C
Tolerance class according to EN 60751	AA A B
Mode of connection	2- 3- 4-conductor connection
Protection capsule	VA-capsule
Dimensions	from $\varnothing = 1$ mm in 0.5 mm steps, length from 20 mm
Sheathed line	Mineral insulated VA-line
Dimensions	$\varnothing 1$ 1.5 2 3 4.5 6 mm*), length upon customer's request *) \varnothing from 3 mm – double measuring resistor
Connection type	- Cable junction capsule with fix connected inlet - Lemosa-plug - connection head form B - bare connection wires



Connection line

Case insulation

hose line

PVC | Silicone | PTFE
Tmax.= 90°C / 180°C / 260°C

Cable length

upon customer's request

Cross-section

AWG 20 | 22 | 24 | 26 | 28

Cable ends

bare | tinned | cable end sleeves

Colour code

according to EN 60751, or upon customer's request

Assembly (optional)

shiftable clamp screw connection | fix screw adapter

Thread

M10x1 | G1/4" | G3/8" | G1/2" | G1"

Clamping Ring *)

Steel | PTFE

*) only at clamp screw connection

Leuchtturm Automation



APPENDIX

General guidelines for the cable confectioning

The cable lengths of the single sensors are usually free selectable. Standard all cable ends are stripped and tin-coated. If required, also cable ends are deliverable with cable end sleeves, with flat or pin contacts, as well as with Lemos-plugs / clutches in 2-, 3- or 4-pole version. Upon request, we also mount plugs supplied by you.

Clamp screw connections

The screw connections listed in the table are optionally deliverable for cable resistance thermometers M-XX/MH, as well as for all screw-in thermometers without fix screw connection from a diameter of 4 mm.

Shiftable VA-screw connections							
	G thread	D [mm]	L [mm]	L1 [mm]	SW1 [mm]	SW2 [mm]	claming ring
	M10x1	13,8	33	8	14	14	PTFE VA Ms
	G 1/4"	18	38	12	19	14	PTFE VA Ms
	G 3/8"	22	40	12	22	14	PTFE VA Ms
	G 1/2"	26	43	14	27	17	PTFE VA Ms
	G 3/4"	32	43	20	32	17	PTFE VA Ms



Application temperatures of the used materials / insulations

The values listed in the table are normative values. They may vary according to the conditions of use and composition of the material.

Material	T _{min} [°C]	T _{max} [°C]
PVC	-40	105
Polyolefin	-40	135
Kynar	-40	175
Silicone	-40	180
HGW Isoval11	-50	180
Kynar Flex	-40	195
FEP	-70	200
HGW Isoval200	-50	200
LGLS	-40	230
PTFE	-200	260
PFA	-70	260
Kapton foil	-40	180
Glass Silk	-60	400
Mica	-60	600
VA-Steel	-200	800
Rude GlassSilk	-40	600
Al ₂ O ₃ -Ceramics	-70	1000
Inconel	-200	1100

Leuchtturm Automation



Index of abbreviations

E	
EFG	single side flat closed
EL	installation length
ERG	single side round closed
F	
FSL	ribbon cable hose line
G	
GL	total length
GS	spun glass
H	
HGW	hard-glass fibre
HL	neck tube length
K	
KL	cable length
KÜH	connection sleeve
M	
MI	mineral insulated
Ms	brass
N	
NL	rated length
NWT	slot resistance thermometer
P	
Pt	platinum
PTFE	poly-tetra-fluorine-ethylene
S	
SL	hose line
Si	silicone
SGH	screw housing
SW	spanner size
V	
VSB	screw connection



Leuchtturm Automation Co., Ltd.
深圳市朝瑞自动化系统有限公司



HKCFS Co., LTD.
创富世（香港）有限公司

联系人：卢有辉

电话：+852-3955 0525 (HK)

座机：+86 0755-2641 8956 (China)

手机：+852 9603 5397 (HK)

手机：+86 150 0022 5131 (China)

传真：+86 0755-8696 2729

邮箱：jerry@cfs-autos.com

网址：<http://www.cfs-autos.com>